



INDUSTRIAL DIRECT DRIVE 20

Electric Heated Air Curtain

Data Sheet

For Mounting Heights To 20' (environmental separation)

STANDARD CONSTRUCTION

- Single speed T.E.A.O. motor(s) - direct drive
- Gray powder coated exterior (Optional: Custom Color or Stainless)
- Split cabinet construction for fan assembly removal
- Top Mounting only
- Front air intake only
- High efficiency Pro-V Nozzle

- Open helical element with point suspension
 - Thermal overload protection
 - Galvanized steel frame
- Factory mounted heater control panel(s)
- Alternate kW: Consult factory

**2 Year
Limited
Warranty**



MODEL	Nozzle Width (in)	Max Vel. at Nozzle (fpm)	Avg. Outlet Vel. (fpm)	Air Volume (cfm)	Outlet Vel. Uniformity	Power Rating (kW)	Motor(s) @ hp	Electric Capacity (kW)	Heater Output (MBH)	Air Temp. Rise (°F)	Net Wt. (lbs)
IDC20-1060E	60.00	6,580	3,870	6,854	89%	4.70	1 @ 5	59.0	201.4	27°	770
IDC20-1072E	72.00	6,549	3,852	8,186	89%	4.90	1 @ 5	65.0	221.8	25°	855
IDC20-1084E	84.00	6,076	3,574	8,861	87%	4.90	1 @ 5	71.0	242.3	25°	940
IDC20-1096E	96.00	6,900	4,059	11,500	92%	6.80	1 @ 7½	92.0	314.0	25°	1,110
IDC20-1108E	108.00	6,747	3,969	12,650	90%	6.90	1 @ 7½	102.0	348.1	25°	1,195
IDC20-1120E	117.00	7,494	4,523	15,612	88%	8.70	1 @ 10	103.0	351.5	21°	1,340
IDC20-1132E	132.00	7,017	4,127	16,080	87%	8.90	1 @ 10	2 @ 65.0	443.7	25°	1,425
IDC20-1144E	144.00	7,640	4,381	19,100	87%	11.70	1 @ 15	2 @ 76.0	518.8	25°	1,555
IDC20-1156E	156.00	7,405	4,356	20,055	86%	11.90	1 @ 15	2 @ 80.0	546.1	25°	1,640
IDC20-1168E	168.00	7,783	4,323	22,700	90%	12.80	1 @ 15	2 @ 91.0	621.2	25°	1,845
IDC20-1180E	180.00	7,300	4,294	22,814	91%	12.90	1 @ 15	2 @ 91.0	621.2	25°	1,930
IDC20-2192E	192.00	6,900	4,059	23,000	92%	13.60	2 @ 7½	2 @ 92.0	628.0	25°	2,150

NOTES:

1. Operation at 50 Hz will generate approximately a 17% reduction in performance.
2. Performance data based on AMCA licensed data from unheated units.
3. Maximum leaving air temperature shall not exceed 120°F.
4. Consult factory for vertically mounted units.

See sheet EP-442 for amp draws/total load requirements.

MODEL NUMBER CONFIGURATION

IDC20-1 060 E D-590-F-SS

Series	# of Motors	Opening Width	Heat	Voltage	Standard kW	Intake	Opt. Cabinet Finish
IDC20	1, 2	060" - 192"	E=Electric Heated	D=208/3/60 E=240/3/60 H=480/3/60 I=600/3/60 T=380/3/50	59.0 - 184.0 (590 - 1840)	F=Front	SS=Stainless Steel CC=Custom Color

See sheet EP-442 for alternate kW code

Sound level measured 10' (3m) from the unit in free field:
5, 7½, 10, 15 & (7½ + 7½) hp motor(s):
73 dBA, 75 dBA, 76 dBA, 78 dBA & 78 dBA
Sound data is not AMCA certified.

Berner reserves the right to alter specifications without prior notice.

www.berner.com Berner International 800.245.4455
111 Progress Ave. / New Castle / PA / 16101 / USA

DS-442
May, 2022



INDUSTRIAL DIRECT DRIVE 20

Electric Heated Air Curtain

Electrical Performance Sheet

208/3/60 (voltage code D)										240/3/60 (voltage code E)							
TOTAL MOTOR AMP DRAW										TOTAL MOTOR AMP DRAW							
				SEPARATE MOTOR & HEATER(S) PANEL			MOTOR CONTROL WITHIN HTR PANEL							SEPARATE MOTOR & HEATER(S) PANEL		MOTOR CONTROL WITHIN HTR PANEL	
MODEL	kW (code)	Temp Rise °F	Qty @ HP	# CKTS	AMPS PER CIRCUIT	BREAKER RATING PER CIRCUIT	# CKTS	AMPS PER CIRCUIT (including motor)	BREAKER RATING PER CIRCUIT	# CKTS	AMPS PER CIRCUIT	BREAKER RATING PER CIRCUIT	# CKTS	AMPS PER CIRCUIT (including motor)	BREAKER RATING PER CIRCUIT		
IDC20-1060E	59 (0590)	25	1 @ 5	2	17.0/163.8	35/225	1	180.8	250	2	15.8/141.9	35/200	1	157.7	200		
IDC20-1072E	65 (0650)	25	1 @ 5	2	17.0/180.4	35/225	1	197.4	250	2	15.8/156.4	35/200	1	172.2	225		
IDC20-1084E	71 (0710)	25	1 @ 5	2	17.0/197.1	35/250	1	214.1	300	2	15.8/170.8	35/225	1	186.6	250		
IDC20-1096E	92 (0920)	25	1 @ 7.5	2	23.0/255.4	50/350	1	278.4	350	2	22.0/221.3	45/300	1	243.3	350		
IDC20-1108E	102 (1020)	25	1 @ 7.5	2	23.0/283.1	50/400	1	306.1	400	2	22.0/245.4	45/350	1	267.4	350		
IDC20-1120E	103 (1030)	21	1 @ 10	2	31.5/285.9	60/400	1	317.4	400	2	30.6/247.8	60/350	1	278.4	350		
IDC20-1132E	2 @ 65 (1300)	25	1 @ 10	3	31.5/180.4/180.4	60/225/225	2	211.9/180.4	300/225	3	30.6/156.4/156.4	60/225/225	2	187.0/156.4	250/200		
IDC20-1144E	2 @ 76 (1520)	25	1 @ 15	3	46.0/211.0/211.0	100/275/275	2	257.0/211.0	350/300	3	44.0/182.8/182.8	100/250/250	2	226.8/182.8	300/250		
IDC20-1156E	2 @ 80 (1600)	25	1 @ 15	3	46.0/222.1/222.1	100/300/300	2	268.1/222.1	350/300	3	44.0/192.5/192.5	100/250/250	2	236.5/192.5	300/250		
IDC20-1168E	2 @ 91 (1820)	25	1 @ 15	3	46.0/252.6/252.6	100/350/350	2	298.6/252.6	400/350	3	44.0/218.9/218.9	100/300/300	2	262.9/218.9	350/300		
IDC20-1180E	2 @ 91 (1820)	25	1 @ 15	3	46.0/252.6/252.6	100/350/350	2	298.6/252.6	400/350	3	44.0/218.9/218.9	100/300/300	2	262.9/218.9	350/300		
IDC20-2192E	2 @ 92 (1840)	25	2 @ 7.5	3	46.0/255.4/255.4	70/350/350	2	301.4/255.4	400/350	3	44.0/221.3/221.3	70/300/300	2	265.3/221.3	350/300		



INDUSTRIAL DIRECT DRIVE 20

Electric Heated Air Curtain

Electrical Performance Sheet

MODEL	kW (code)	Temp Rise °F	Qty @ HP	# CKTS	480/3/60 (voltage code H)					600/3/60 (voltage code I)					
					TOTAL MOTOR AMP DRAW					TOTAL MOTOR AMP DRAW					
					SEPARATE MOTOR & HEATER(S) PANEL		MOTOR CONTROL WITHIN HTR PANEL			SEPARATE MOTOR & HEATER(S) PANEL		MOTOR CONTROL WITHIN HTR PANEL			
					AMPS PER CIRCUIT	BREAKER RATING PER CIRCUIT	# CKTS	AMPS PER CIRCUIT (including motor)	BREAKER RATING PER CIRCUIT	# CKTS	AMPS PER CIRCUIT	BREAKER RATING PER CIRCUIT	# CKTS	AMPS PER CIRCUIT (including motor)	BREAKER RATING PER CIRCUIT
IDC20-1060E	59 (0590)	25	1 @ 5	2	7.9/71.0	20/100	1	78.9	100	2	6.3/59.2	15/100	1	65.5	100
IDC20-1072E	65 (0650)	25	1 @ 5	2	7.9/78.2	20/100	1	86.1	125	2	6.3/65.3	15/100	1	71.6	100
IDC20-1084E	71 (0710)	25	1 @ 5	2	7.9/85.4	20/125	1	93.3	125	2	6.3/71.3	15/100	1	77.6	100
IDC20-1096E	92 (0920)	25	1 @ 7.5	2	11.0/110.7	25/125	1	121.7	175	2	8.5/92.4	20/100	1	100.9	150
IDC20-1108E	102 (1020)	25	1 @ 7.5	2	11.0/122.7	25/175	1	133.7	175	2	8.5/102.4	20/150	1	110.9	150
IDC20-1120E	103 (1030)	21	1 @ 10	2	15.3/123.9	30/175	1	139.2	175	2	11.7/103.4	25/150	1	115.1	150
IDC20-1132E	2 @ 65 (1300)	25	1 @ 10	3	15.3/78.2/78.2	30/100/100	2	93.5/78.2	125/100	3	11.7/65.3/65.3	25/100/100	2	77.0/65.3	100/100
IDC20-1144E	2 @ 76 (1520)	25	1 @ 15	3	22.0/91.4/91.4	45/125/125	2	113.4/91.4	150/125	3	17.5/76.3/76.3	35/100/100	2	93.8/76.3	125/100
IDC20-1156E	2 @ 80 (1600)	25	1 @ 15	3	22.0/96.2/96.2	45/125/125	2	118.2/96.2	150/125	3	17.5/80.3/80.3	35/100/100	2	97.8/80.3	125/100
IDC20-1168E	2 @ 91 (1820)	25	1 @ 15	3	22.0/109.5/109.5	45/150/150	2	131.5/109.5	175/150	3	17.5/91.4/91.4	35/125/125	2	108.9/91.4	150/125
IDC20-1180E	2 @ 91 (1820)	25	1 @ 15	3	22.0/109.5/109.5	45/150/150	2	131.5/109.5	175/150	3	17.5/91.4/91.4	35/125/125	2	108.9/91.4	150/125
IDC20-2192E	2 @ 92 (1840)	25	2 @ 7.5	3	22.0/110.7/110.7	35/150/150	2	132.7/110.7	175/150	3	17.0/91.4/91.4	30/125/125	2	109.4/92.4	150/125



INDUSTRIAL DIRECT DRIVE 20

Electric Heated Air Curtain
Electrical Performance Sheet

380/3/50 (voltage code T)									
TOTAL MOTOR AMP DRAW									
					SEPARATE MOTOR & HEATER(S) PANEL		MOTOR CONTROL WITHIN HTR PANEL		
MODEL	kW (code)	Temp Rise °F	Qty @ HP	# CKTS	AMPS PER CIRCUIT	BREAKER RATING PER CIRCUIT	# CKTS	AMPS PER CIRCUIT (including motor)	BREAKER RATING PER CIRCUIT
IDC20-1060E	59 (0590)	25	1 @ 5	2	7.7/89.6	20/125	1	97.3	125
IDC20-1072E	65 (0650)	25	1 @ 5	2	7.7/98.8	20/125	1	106.5	150
IDC20-1084E	71 (0710)	25	1 @ 5	2	7.7/107.9	20/150	1	115.6	150
IDC20-1096E	92 (0920)	25	1 @ 7.5	2	9.0/139.8	20/175	1	148.8	200
IDC20-1108E	102 (1020)	25	1 @ 7.5	2	9.0/155.0	20/200	1	164.0	225
IDC20-1120E	103 (1030)	21	1 @ 10	2	12.5/156.5	25/200	1	169.0	225
IDC20-1132E	2 @ 65 (1300)	25	1 @ 10	3	12.5/98.8/98.8	25/125/125	2	111.3/98.8	150/125
IDC20-1144E	2 @ 76 (1520)	25	1 @ 15	3	18.0/115.5/115.5	40/150/150	2	133.5/115.5	175/150
IDC20-1156E	2 @ 80 (1600)	25	1 @ 15	3	18.0/121.5/121.5	40/175/175	2	139.5/121.5	200/175
IDC20-1168E	2 @ 91 (1820)	25	1 @ 15	3	18.0/138.3/138.3	40/175/175	2	156.3/138.3	200/175
IDC20-1180E	2 @ 91 (1820)	25	1 @ 15	3	18.0/138.3/138.3	40/175/175	2	156.3/138.3	200/175
IDC20-2192E	2 @ 92 (1840)	25	2 @ 7.5	3	18.0/139.8/139.8	40/175/175	2	157.8/139.8	200/175

IDC20 ELECTRIC HEATED FRONT INTAKE ONE HEATER SYSTEM

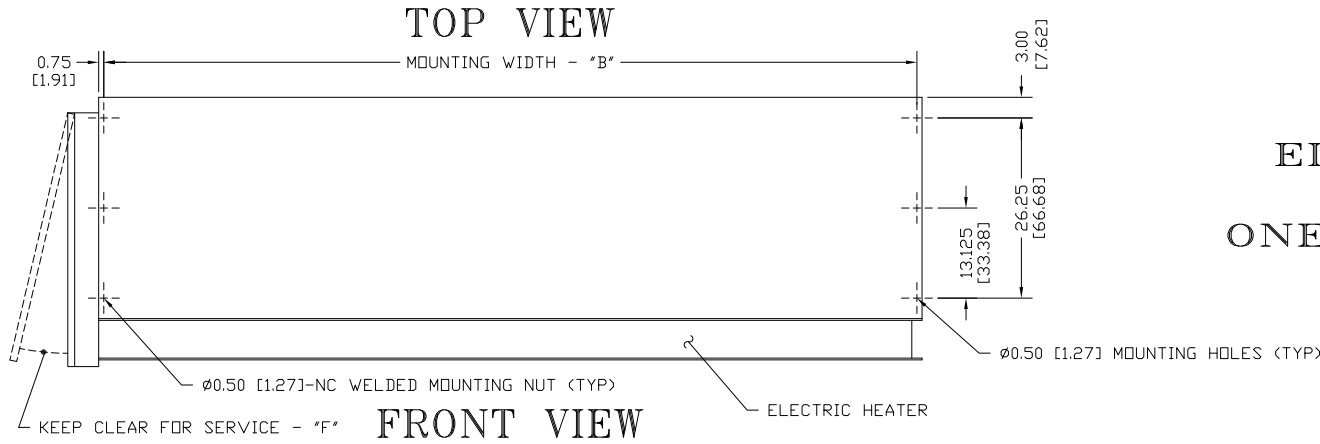

END VIEW

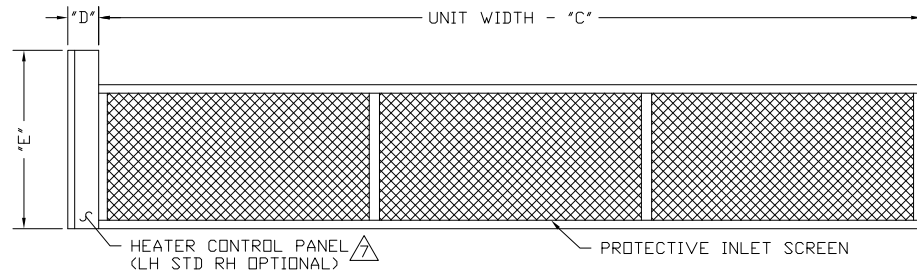
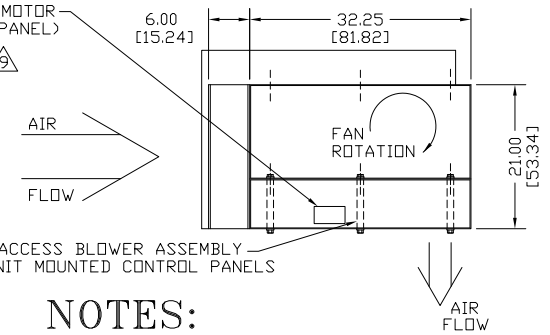

BOTTOM VIEW

NOTES:

- 1 AIR CURTAIN MUST BE INSTALLED SO AIR STREAM IS NOT OBSTRUCTED WHEN DEFLECTED 20° TO EITHER SIDE OF C.
- 2 ELECTRICAL CONNECTIONS TO BE FLEXIBLE.
- 3 FIELD VERIFY DIMENSIONS.
- 4 ANCHORS TO SUPPORTING STRUCTURE BY OTHERS.
- 5 ADEQUACY OF SUPPORTING STRUCTURE IS TO BE VERIFIED BY A PROFESSIONAL STRUCTURAL ENGINEER.
- 6 LETTER 'E' IN MODEL NUMBER DESIGNATES, ELECTRIC HEATED UNIT. THE 'F' DESIGNATES FRONT INTAKE.
- 7 HEATER CONTROL PANEL SHOWN LEFT HAND, RIGHT HAND AVAILABLE, PLEASE SPECIFY.
- 8 HEATER CONTROL PANEL INCLUDES POWER FUSING, AIR FLOW SWITCH, AND CONTROL CIRCUIT TRANSFORMER.
- 9 TO INCLUDE MOTOR STARTER IN HEATER CONTROL PANEL, REFER TO DRAWING IDC20-ELE1X.
- 10 DIMENSIONS IN INCHES [CENTIMETERS].

MODEL	NOZZLE WIDTH "A"	MOUNTING WIDTH "B"	UNIT WIDTH "C"	HEATER CAPACITY (KW)	HEATER CONTROL PANEL DIMENSIONS BASED ON VOLTAGE											
					"D"				"E"				"F"			
					208V	230V	460V	575V	208V	230V	460V	575V	208V	230V	460V	575V
IDC20-1060E-F	60.00 [152.40]	61.50 [156.21]	63.00 [160.02]	59	6.00 [15.24]	6.00 [11.43]	4.50 [11.43]	4.50 [11.43]	23.50 [59.69]	23.50 [59.69]	23.50 [59.69]	23.50 [59.69]	35.00 [88.90]	29.00 [73.66]	26.00 [66.04]	26.00 [66.04]
IDC20-1072E-F	72.00 [182.88]	73.50 [186.69]	75.00 [190.50]	65	6.00 [15.24]	6.00 [11.43]	4.50 [11.43]	4.50 [11.43]	23.50 [59.69]	23.50 [59.69]	23.50 [59.69]	23.50 [59.69]	35.00 [88.90]	35.00 [88.90]	26.00 [66.04]	26.00 [66.04]
IDC20-1084E-F	84.00 [213.36]	85.50 [217.17]	87.00 [220.98]	71	6.00 [15.24]	6.00 [11.43]	4.50 [11.43]	4.50 [11.43]	27.00 [68.58]	23.50 [59.69]	23.50 [59.69]	23.50 [59.69]	39.00 [99.06]	35.00 [88.90]	26.00 [66.04]	26.00 [66.04]
IDC20-1096E-F	96.00 [243.84]	97.50 [247.65]	99.00 [251.46]	92	8.50 [20.32]	6.00 [11.43]	6.00 [15.24]	4.50 [11.43]	27.00 [68.58]	27.00 [68.58]	23.50 [59.69]	23.50 [59.69]	43.50 [110.49]	39.00 [99.06]	32.00 [81.28]	26.00 [66.04]
IDC20-1108E-F	108.00 [274.32]	109.50 [278.13]	111.00 [281.94]	102	8.50 [20.32]	8.50 [20.32]	6.00 [15.24]	6.00 [15.24]	27.00 [68.58]	27.00 [68.58]	23.50 [59.69]	23.50 [59.69]	43.50 [110.49]	43.50 [110.49]	32.00 [81.28]	32.00 [81.28]
IDC20-1120E-F	117.00 [297.18]	118.50 [300.99]	120.00 [304.80]	103	8.50 [20.32]	8.50 [20.32]	6.00 [15.24]	6.00 [15.24]	27.00 [68.58]	27.00 [68.58]	26.00 [66.04]	23.50 [59.69]	43.50 [110.49]	43.50 [110.49]	37.00 [93.98]	32.00 [81.28]

PROJECT		
LOCATION		
ARCHITECT		
ENGINEER		
DWG. NO.	IDC20-ELE1	TITLE: BERNER
DATE	14DEC20	MODEL IDC20 AIR CURTAIN
BY	S. Beil	FRONT INTAKE ELECTRIC ONE HEATER SYSTEM
REPLACES	30JUN16	
BY	D. Johnson	BERNER INTERNATIONAL CORP. NEW CASTLE, PA.

IDC20

ELECTRIC HEATED FRONT INTAKE ONE HEATER SYSTEM WITH MOTOR CONTROL

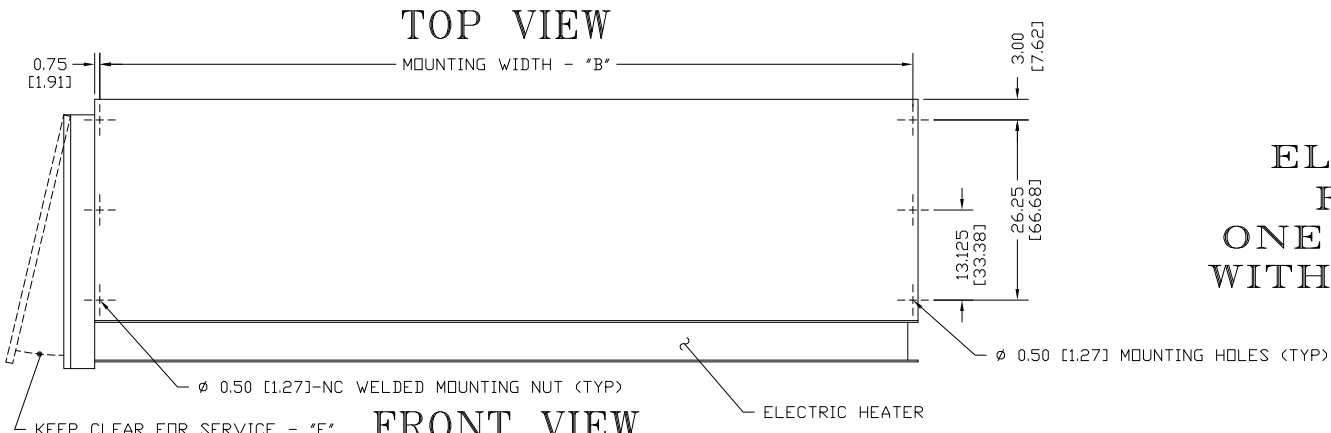

END VIEW

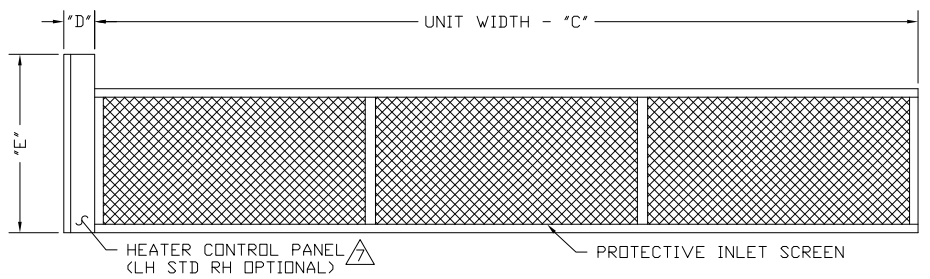
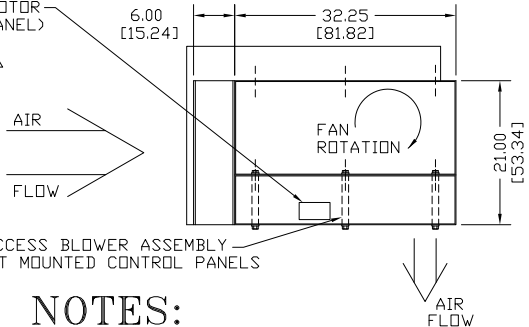

NOTES:

- 1 AIR CURTAIN MUST BE INSTALLED SO AIR STREAM IS NOT OBSTRUCTED WHEN DEFLECTED 20° TO EITHER SIDE OF C.
- 2 ELECTRICAL CONNECTIONS TO BE FLEXIBLE.
- 3 FIELD VERIFY DIMENSIONS.
- 4 ANCHORS TO SUPPORTING STRUCTURE BY OTHERS.
- 5 ADEQUACY OF SUPPORTING STRUCTURE IS TO BE VERIFIED BY A PROFESSIONAL STRUCTURAL ENGINEER.
- 6 LETTER 'E' IN MODEL NUMBER DESIGNATES, ELECTRIC HEATED UNIT. THE 'F' DESIGNATES FRONT INTAKE.
- 7 HEATER CONTROL PANEL SHOWN LEFT HAND, RIGHT HAND AVAILABLE, PLEASE SPECIFY.
- 8 HEATER CONTROL PANEL INCLUDES POWER FUSING, AIR FLOW SWITCH, AND CONTROL CIRCUIT TRANSFORMER.
- 9 TO INCLUDE MOTOR STARTER IN HEATER CONTROL PANEL, REFER TO DRAWING IDC20-ELE1 FOR DIMENSIONS W/O.
- 10 DIMENSIONS IN INCHES [CENTIMETERS].

MODEL	NOZZLE WIDTH 'A'	MOUNTING WIDTH 'B'	UNIT WIDTH 'C'	HEATER CAPACITY (KW)	HEATER CONTROL PANEL DIMENSIONS BASED ON VOLTAGE											
					'D'				'E'				'F'			
					208V	230V	460V	575V	208V	230V	460V	575V	208V	230V	460V	575V
IDC20-1060E-F	60.00 [152.40]	61.50 [156.21]	63.00 [160.02]	59	6.00 [15.24]	6.00 [11.43]	6.00 [15.24]	6.00 [15.24]	27.00 [68.58]	23.50 [59.69]	23.50 [59.69]	23.50 [59.69]	37.00 [93.98]	35.00 [88.90]	32.00 [81.28]	32.00 [81.28]
IDC20-1072E-F	72.00 [182.88]	73.50 [186.69]	75.00 [190.50]	65	6.00 [15.24]	6.00 [11.43]	6.00 [15.24]	6.00 [15.24]	27.00 [68.58]	27.00 [68.58]	23.50 [59.69]	23.50 [59.69]	37.00 [93.98]	37.00 [93.98]	32.00 [81.28]	32.00 [81.28]
IDC20-1084E-F	84.00 [213.36]	85.50 [217.17]	87.00 [220.98]	71	6.00 [15.24]	6.00 [11.43]	6.00 [15.24]	6.00 [15.24]	27.00 [68.58]	27.00 [68.58]	23.50 [59.69]	23.50 [59.69]	45.00 [114.30]	37.00 [93.98]	32.00 [81.28]	32.00 [81.28]
IDC20-1096E-F	96.00 [243.84]	97.50 [247.65]	99.00 [251.46]	92	8.50 [20.32]	6.00 [11.43]	6.00 [15.24]	6.00 [15.24]	27.00 [68.58]	27.00 [68.58]	24.50 [62.23]	23.50 [59.69]	49.00 [124.46]	45.00 [114.30]	37.00 [93.98]	32.00 [81.28]
IDC20-1108E-F	108.00 [274.32]	109.50 [278.13]	111.00 [281.94]	102	8.50 [20.32]	8.50 [20.32]	6.00 [15.24]	6.00 [15.24]	27.00 [68.58]	27.00 [68.58]	24.50 [62.23]	24.50 [62.23]	49.00 [124.46]	49.00 [124.46]	37.00 [93.98]	37.00 [93.98]
IDC20-1120E-F	117.00 [297.18]	118.50 [300.99]	120.00 [304.80]	103	8.50 [20.32]	8.50 [20.32]	6.00 [15.24]	6.00 [15.24]	27.00 [68.58]	27.00 [68.58]	27.00 [68.58]	24.50 [62.23]	49.00 [124.46]	49.00 [124.46]	42.00 [106.68]	37.00 [93.98]

PROJECT		TITLE:	BERNER
LOCATION		DATE:	14DEC20
ARCHITECT		BY:	S. Beil
ENGINEER		REPLACES:	30JUN16
		BY:	D. Johnson
		BERNER INTERNATIONAL CORP. NEW CASTLE, PA.	

IDC20 ELECTRIC HEATED FRONT INTAKE TWO HEATER SYSTEM

TOP VIEW

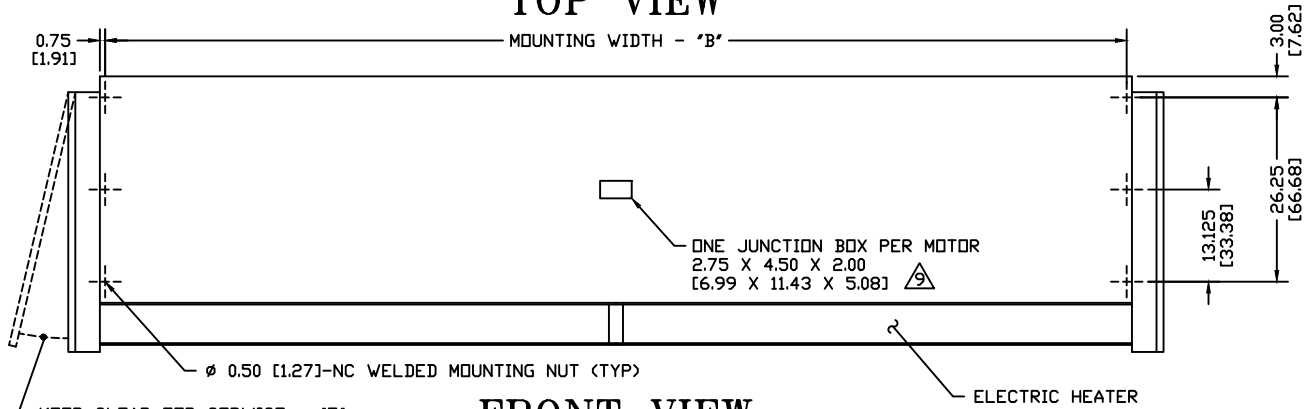

FRONT VIEW

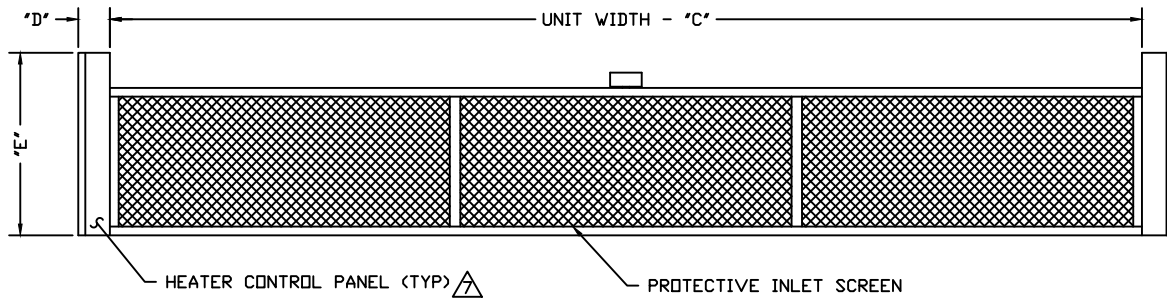

BOTTOM VIEW

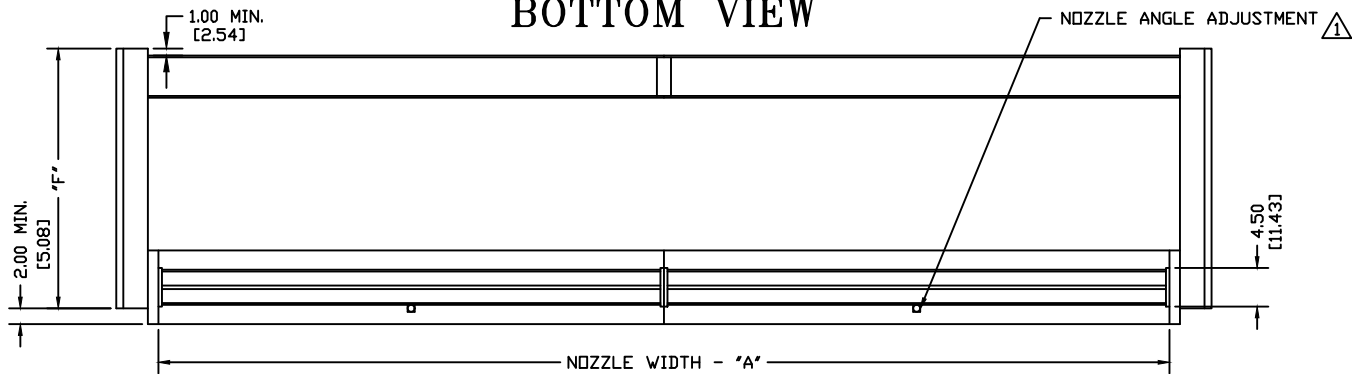

END VIEW (CONTROL PANEL REMOVED)

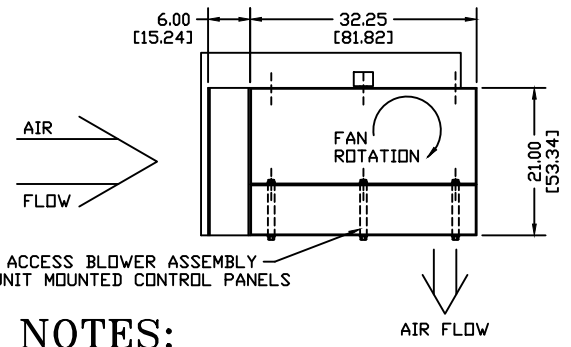

NOTES:

- 1. AIR CURTAIN MUST BE INSTALLED SO AIR STREAM IS NOT OBSTRUCTED WHEN DEFLECTED 20° TO EITHER SIDE OF Q.
- 2. ELECTRICAL CONNECTIONS TO BE FLEXIBLE.
- 3. FIELD VERIFY DIMENSIONS.
- 4. ANCHORS TO SUPPORTING STRUCTURE BY OTHERS.
- 5. ADEQUACY OF SUPPORTING STRUCTURE IS TO BE VERIFIED BY A PROFESSIONAL STRUCTURAL ENGINEER.
- 6. LETTER "E" IN MODEL NUMBER DESIGNATES, ELECTRIC HEATED UNIT. THE "F" DESIGNATES FRONT INTAKE.
- 7. HEATER CONTROL PANELS REQUIRE LEFT HAND & RIGHT HAND. MOTOR CONTROL IS REMOTE EXCEPT AS IN 9.
- 8. HEATER CONTROL PANEL INCLUDES POWER FUSING, AIR FLOW SWITCH, AND CONTROL CIRCUIT TRANSFORMER.
- 9. TO INCLUDE MOTOR STARTER IN HEATER CONTROL PANEL, REFER TO DRAWING IDC20-ELE2X.
- 10. DIMENSIONS IN INCHES [CENTIMETERS].

MODEL	NOZZLE WIDTH "A"	MOUNTING WIDTH "B"	UNIT WIDTH "C"	HEATER CAPACITY (KW)	HEATER CONTROL PANEL DIMENSIONS BASED ON VOLTAGE											
					"D"				"E"				"F"			
					208V	230V	460V	575V	208V	230V	460V	575V	208V	230V	460V	575V
IDC20-1132E-F	132.00 [335.28]	133.50 [339.09]	135.00 [342.90]	2 @ 65	6.00 [15.24]	6.00 [15.24]	4.50 [11.43]	4.50 [11.43]	23.50 [59.69]	23.50 [59.69]	23.50 [59.69]	23.50 [59.69]	35.00 [88.90]	35.00 [88.90]	26.00 [66.04]	26.00 [66.04]
IDC20-1144E-F	144.00 [365.76]	145.50 [369.57]	147.00 [373.38]	2 @ 76	6.00 [15.24]	6.00 [15.24]	4.50 [11.43]	4.50 [11.43]	27.00 [68.58]	23.50 [59.69]	23.50 [59.69]	23.50 [59.69]	39.00 [99.06]	35.00 [88.90]	26.00 [66.04]	26.00 [66.04]
IDC20-1156E-F	156.00 [396.24]	157.50 [400.05]	159.00 [403.86]	2 @ 80	6.00 [15.24]	6.00 [15.24]	6.00 [15.24]	4.50 [11.43]	27.00 [68.58]	27.00 [68.58]	23.50 [59.69]	23.50 [59.69]	39.00 [99.06]	39.00 [99.06]	32.00 [81.28]	26.00 [66.04]
IDC20-1168E-F	168.00 [426.72]	169.50 [430.53]	171.00 [434.34]	2 @ 91	8.50 [20.32]	6.00 [15.24]	6.00 [15.24]	4.50 [11.43]	27.00 [68.58]	27.00 [68.58]	23.50 [59.69]	23.50 [59.69]	43.50 [110.49]	39.00 [99.06]	29.00 [73.66]	26.00 [66.04]
IDC20-1180E-F	180.00 [457.20]	181.50 [461.01]	183.00 [464.82]	2 @ 91	8.50 [20.32]	6.00 [15.24]	6.00 [15.24]	4.50 [11.43]	27.00 [68.58]	27.00 [68.58]	23.50 [59.69]	23.50 [59.69]	43.50 [110.49]	39.00 [99.06]	32.00 [81.28]	26.00 [66.04]
IDC20-2192E-F	192.00 [487.68]	193.50 [491.49]	195.00 [495.30]	2 @ 92	8.50 [20.32]	6.00 [15.24]	6.00 [15.24]	4.50 [11.43]	27.00 [68.58]	27.00 [68.58]	23.50 [59.69]	23.50 [59.69]	43.50 [110.49]	39.00 [99.06]	32.00 [81.28]	26.00 [66.04]

PROJECT		
LOCATION		
ARCHITECT		
ENGINEER		
DWG. NO.	IDC20-ELE2	TITLE: BERNER
DATE	14APR2021	MODEL IDC20 AIR CURTAIN
BY	AJohnston	FRONT INTAKE ELECTRIC TWO HEATER SYSTEM
REPLACES	12DEC2020	
BY	S. Bell	BERNER INTERNATIONAL CORP. NEW CASTLE, PA.

TOP VIEW

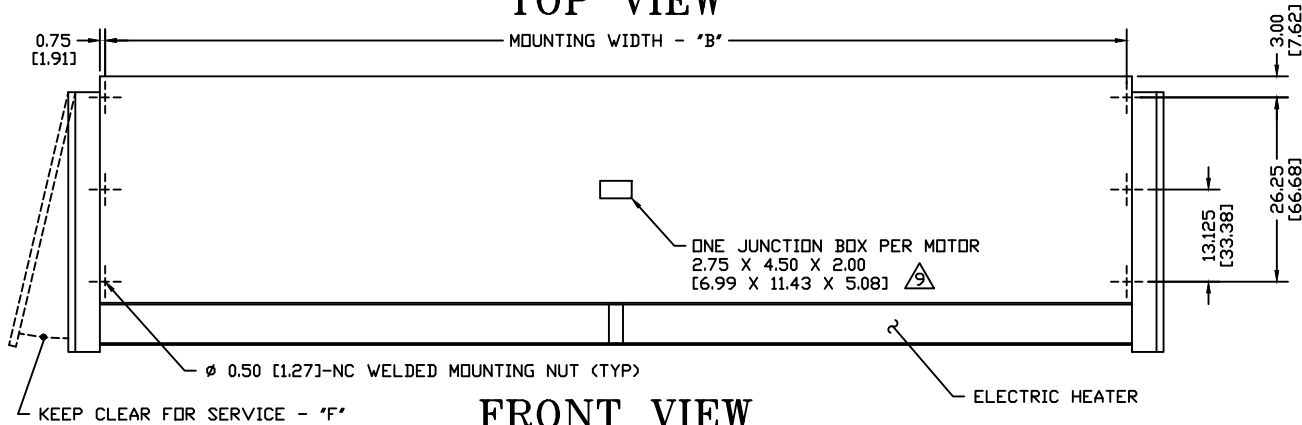

FRONT VIEW

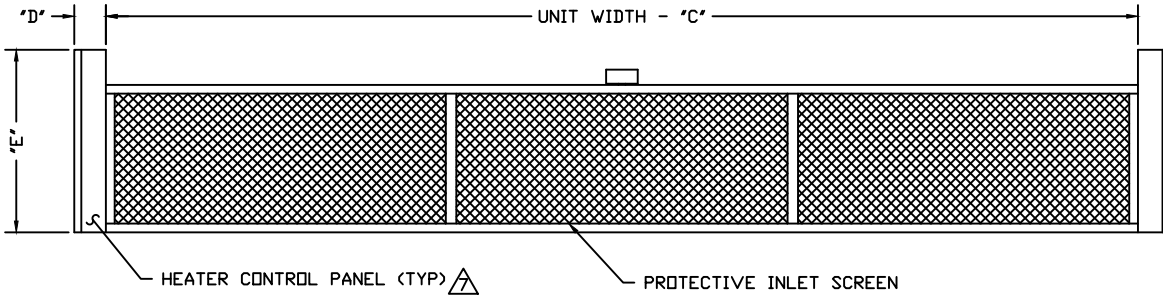

BOTTOM VIEW

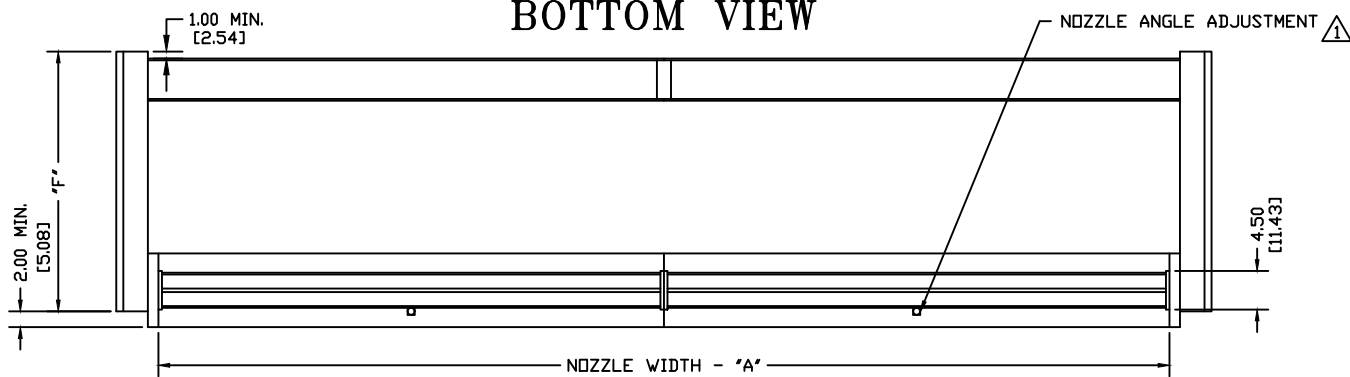

IDC20

ELECTRIC HEATED FRONT INTAKE TWO HEATER SYSTEM WITH MOTOR CONTROL

END VIEW (CONTROL PANEL REMOVED)

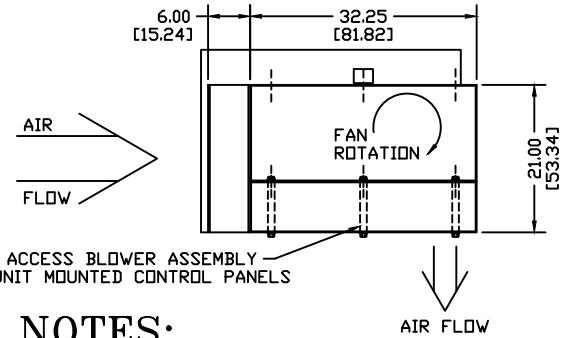

NOTES:

- ⚠️ AIR CURTAIN MUST BE INSTALLED SO AIR STREAM IS NOT OBSTRUCTED WHEN DEFLECTED 20° TO EITHER SIDE OF Q.
- ⚠️ ELECTRICAL CONNECTIONS TO BE FLEXIBLE.
- ⚠️ FIELD VERIFY DIMENSIONS.
- ⚠️ ANCHORS TO SUPPORTING STRUCTURE BY OTHERS.
- ⚠️ ADEQUACY OF SUPPORTING STRUCTURE IS TO BE VERIFIED BY A PROFESSIONAL STRUCTURAL ENGINEER.
- ⚠️ LETTER 'E' IN MODEL NUMBER DESIGNATES, ELECTRIC HEATED UNIT. THE 'F' DESIGNATES FRONT INTAKE.
- ⚠️ HEATER CONTROL PANELS REQUIRE LEFT HAND & RIGHT HAND. MOTOR CONTROL IS REMOTE EXCEPT AS IN ⚠️.
- ⚠️ HEATER CONTROL PANEL INCLUDES POWER FUSING, AIR FLOW SWITCH, AND CONTROL CIRCUIT TRANSFORMER.
- ⚠️ TO INCLUDE MOTOR STARTER IN HEATER CONTROL PANEL REFER TO DRAWING IDC16-ELE1 FOR DIMENSIONS W/D.
- ⚠️ DIMENSIONS IN INCHES [CENTIMETERS].

MODEL ⚠️	NOZZLE WIDTH 'A'	MOUNTING WIDTH 'B'	UNIT WIDTH 'C'	HEATER CAPACITY (KW)	HEATER CONTROL PANEL DIMENSIONS BASED ON VOLTAGE ⚠️											
					'D'				'E'				'F'			
					208V	230V	460V	575V	208V	230V	460V	575V	208V	230V	460V	575V
IDC20-1132E-F	132.00 [335.28]	133.50 [339.09]	135.00 [342.90]	2 @ 65	6.00 [15.24]	6.00 [15.24]	6.00 [15.24]	6.00 [15.24]	27.00 [68.58]	27.00 [68.58]	23.50 [59.69]	23.50 [59.69]	37.00 [93.98]	37.00 [93.98]	32.00 [81.28]	32.00 [81.28]
IDC20-1144E-F	144.00 [365.76]	145.50 [369.57]	147.00 [373.38]	2 @ 76	6.00 [15.24]	6.00 [15.24]	6.00 [15.24]	6.00 [15.24]	27.00 [68.58]	27.00 [68.58]	23.50 [59.69]	23.50 [59.69]	45.00 [114.30]	37.00 [93.98]	32.00 [81.28]	32.00 [81.28]
IDC20-1156E-F	156.00 [396.24]	157.50 [400.05]	159.00 [403.86]	2 @ 80	6.00 [15.24]	6.00 [15.24]	6.00 [15.24]	6.00 [15.24]	27.00 [68.58]	27.00 [68.58]	24.50 [62.23]	23.50 [59.69]	45.00 [114.30]	37.00 [93.98]	32.00 [81.28]	32.00 [81.28]
IDC20-1168E-F	168.00 [426.72]	169.50 [430.53]	171.00 [434.34]	2 @ 91	8.50 [20.32]	6.00 [15.24]	6.00 [15.24]	6.00 [15.24]	27.00 [68.58]	27.00 [68.58]	23.50 [59.69]	23.50 [59.69]	49.00 [124.46]	45.00 [114.30]	35.00 [88.90]	32.00 [81.28]
IDC20-1180E-F	180.00 [457.20]	181.50 [461.01]	183.00 [464.82]	2 @ 91	8.50 [20.32]	6.00 [15.24]	6.00 [15.24]	6.00 [15.24]	27.00 [68.58]	27.00 [68.58]	24.50 [62.23]	23.50 [59.69]	49.00 [124.46]	45.00 [114.30]	37.00 [93.98]	32.00 [81.28]
IDC20-2192E-F	192.00 [487.68]	193.50 [491.49]	195.00 [495.30]	2 @ 92	8.50 [20.32]	6.00 [15.24]	6.00 [15.24]	6.00 [15.24]	27.00 [68.58]	27.00 [68.58]	24.50 [62.23]	23.50 [59.69]	49.00 [124.46]	45.00 [114.30]	37.00 [93.98]	32.00 [81.28]

PROJECT		
LOCATION		
ARCHITECT		
ENGINEER		
DWG. NO.	IDC20-ELE2X	TITLE: BERNER
DATE	14APR2021	MODEL IDC20 AIR CURTAIN
BY	A. Johnston	FRONT INTAKE ELECTRIC TWO HEATER SYSTEM
REPLACES	14DEC2020	
BY	S. Bell	BERNER INTERNATIONAL CORP. NEW CASTLE, PA.