



INDUSTRIAL DIRECT DRIVE 16

Hot Water Heated Air Curtain

Data Sheet

For Mounting Heights To 16' (environmental separation)

STANDARD CONSTRUCTION

- Single speed T.E.A.O. motor(s) - direct drive
- Gray powder coated exterior (Optional: Custom Color or Stainless)
- Split cabinet construction for fan assembly removal
- Top Mounting only
- Front air intake (Optional: top)
- High efficiency Pro-V Nozzle

- Coil Features:
 - Galvanized steel casing
 - 5/8" copper tube with .035" wall
 - Aluminum fins
 - Leak tested at 450 psi

2 Year
Limited
Warranty



MODEL	Nozzle Width (in)	Max Vel. at Nozzle (fpm)	Avg. Outlet Vel. (fpm)	Air Volume (cfm)	Outlet Vel. Uniformity	Power Rating (kW)	Motor(s) @ hp	Coil Output (MBH)	Entering / Leaving Water Temp. (°F)	Water Flow (GPM)	Fluid Pressure Drop (FT. WG.)	Air Temp. Rise (°F)	Net Wt. (lbs)
IDC16-1060W	60.00	5,145	3,302	5,359	85%	2.80	1 @ 3	227.1	180° / 161°	24.0	2.3	39°	467
IDC16-1072W	72.00	5,005	2,944	6,256	91%	2.90	1 @ 3	267.2	180° / 159°	26.0	2.7	39°	520
IDC16-1084W	84.00	4,644	2,732	6,772	89%	3.00	1 @ 3	292.3	180° / 156°	25.0	2.6	39°	573
IDC16-1096W	96.00	5,352	3,148	8,920	87%	4.10	1 @ 5	378.2	180° / 158°	36.0	5.4	39°	687
IDC16-1108W	108.00	5,236	3,080	9,817	86%	4.20	1 @ 5	416.7	180° / 157°	37.0	5.8	39°	820
IDC16-1120W	117.00	6,012	3,627	12,526	87%	4.80	1 @ 7.5	506.5	180° / 158°	47.0	9.4	37°	865
IDC16-1132W	132.00	5,602	3,296	12,839	86%	4.90	1 @ 7.5	536.3	180° / 157°	47.0	9.6	38°	934
IDC16-1144W	144.00	5,225	3,074	13,062	85%	5.40	1 @ 7.5	564.5	180° / 157°	50.0	11.1	39°	987
IDC16-1156W	156.00	4,943	2,908	13,388	84%	5.50	1 @ 7.5	592.1	180° / 157°	52.0	12.2	40°	1,050
IDC16-2168W	168.00	5,203	3,061	15,176	89%	7.00	1 @ 5, 1 @ 3	664.6	180° / 157°	60.0	16.4	40°	1,168
IDC16-2180W	180.00	5,143	3,026	16,073	87%	7.10	1 @ 5, 1 @ 3	705.4	180° / 157°	62.0	17.8	40°	1,249
IDC16-2192W	192.00	5,352	3,148	17,840	87%	8.20	2 @ 5	767.6	180° / 156°	65.0	19.8	39°	1,327

NOTES:

1. Operation at 50 Hz will generate approximately a 17% reduction in performance.
2. Performance data based on AMCA licensed data from unheated units.
3. Coil performance based on 65°F entering air temperature.
4. Standard connection same end supply/return (Optional: opposite end supply/return).
5. Coil should be field supplied with a solenoid valve that energizes only when air curtain is energized. Consideration must be taken for freeze protection when necessary.
6. Maximum leaving air temperature shall not exceed 120°F.
7. Consult factory for alternate entering air & water temperatures, GPM's, opposite end supply/return connections performance data, or vertically mounted units.

See sheet EP-426 for amp draws/total load requirements.

MODEL NUMBER CONFIGURATION

IDC16-1 060 W D-F-SS

Series	# of Motors	Opening Width	Heat	Voltage	Intake	Opt. Cabinet Finish
IDC16	1, 2	060" - 192"	W=Hot Water Heated	D=208/3/60 E=240/3/60 H=480/3/60 I=600/3/60 T=380/3/50	T=Top F=Front	SS=Stainless Steel CC=Custom Color

Sound level measured 10' (3m) from the unit in free field:
3, 5, 7½, (5 + 3) & (5 + 5) hp motor(s):
68 dBA, 70 dBA, 71 dBA, 72 dBA & 73 dBA

Berner reserves the right to alter specifications without prior notice.

www.berner.com **Berner International** 800.245.4455
111 Progress Ave. / New Castle / PA / 16101 / USA

DS-426
January, 2020



INDUSTRIAL DIRECT DRIVE 16

Hot Water Heated Air Curtain

Electrical Performance Sheet

MODEL	Qty @ HP	208/3/60 (voltage code D) MOTOR AMP DRAW PER HP			240/3/60 (voltage code E) MOTOR AMP DRAW PER HP			480/3/60 (voltage code H) MOTOR AMP DRAW PER HP		
		# CKTS	AMPS PER CIRCUIT	BREAKER RATING PER CIRCUIT	# CKTS	AMPS PER CIRCUIT	BREAKER RATING PER CIRCUIT	# CKTS	AMPS PER CIRCUIT	BREAKER RATING PER CIRCUIT
IDC16-1060W IDC16-1072W IDC16-1084W	1 @ 3	1	13.1	25	1	12.2	25	1	6.1	15
IDC16-1096W IDC16-1108W	1 @ 5	1	17.0	35	1	15.8	35	1	7.9	20
IDC16-1120W IDC16-1132W IDC16-1144W IDC16-1156W	1 @ 7.5	1	23.0	50	1	22.0	45	1	11.0	25
IDC16-2168W IDC16-2180W	1 @ 3 1 @ 5	1	30.1	50	1	28.0	60	1	14.0	25
IDC16-2192W	2 @ 5	1	34.0	60	1	31.6	60	1	15.8	25

MODEL	Qty @ HP	600/3/60 (voltage code I) MOTOR AMP DRAW PER HP			380/3/50 (voltage code T) MOTOR AMP DRAW PER HP		
		# CKTS	AMPS PER CIRCUIT	BREAKER RATING PER CIRCUIT	# CKTS	AMPS PER CIRCUIT	BREAKER RATING PER CIRCUIT
IDC16-1060W IDC16-1072W IDC16-1084W	1 @ 3	1	3.9	15	1	5.9	15
IDC16-1096W IDC16-1108W	1 @ 5	1	6.3	15	1	7.7	20
IDC16-1120W IDC16-1132W IDC16-1144W IDC16-1156W	1 @ 7.5	1	8.5	20	1	9.0	20
IDC16-2168W IDC16-2180W	1 @ 3 1 @ 5	1	10.2	20	1	13.6	20
IDC16-2192W	2 @ 5	1	12.6	20	1	15.4	25

Berner reserves the right to alter specifications without prior notice.

www.berner.com **Berner International** 800.245-4455
111 Progress Ave. / New Castle / PA / 16101 / USA

EP-426
March, 2022

IDC16[®]

HOT WATER HEATED TOP INTAKE SAME END SUP./RET.

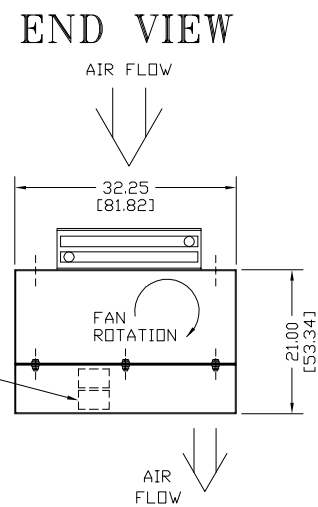
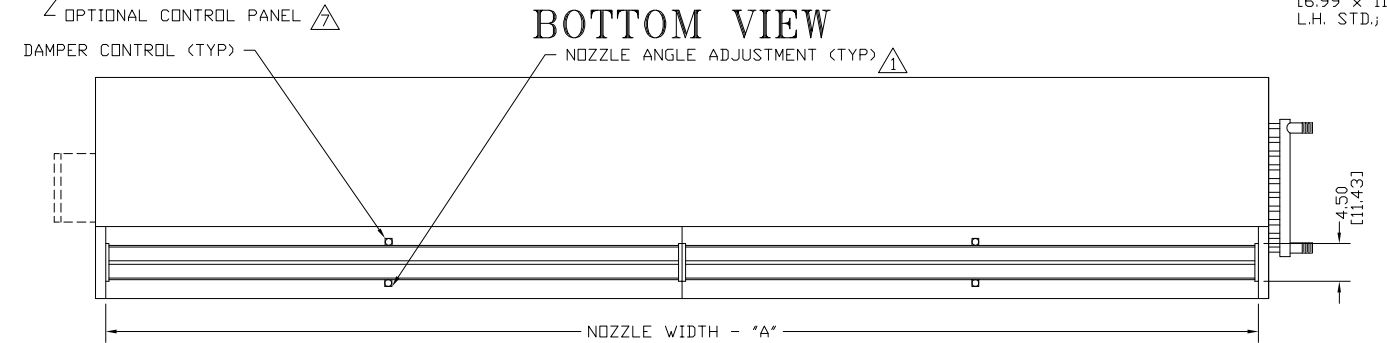
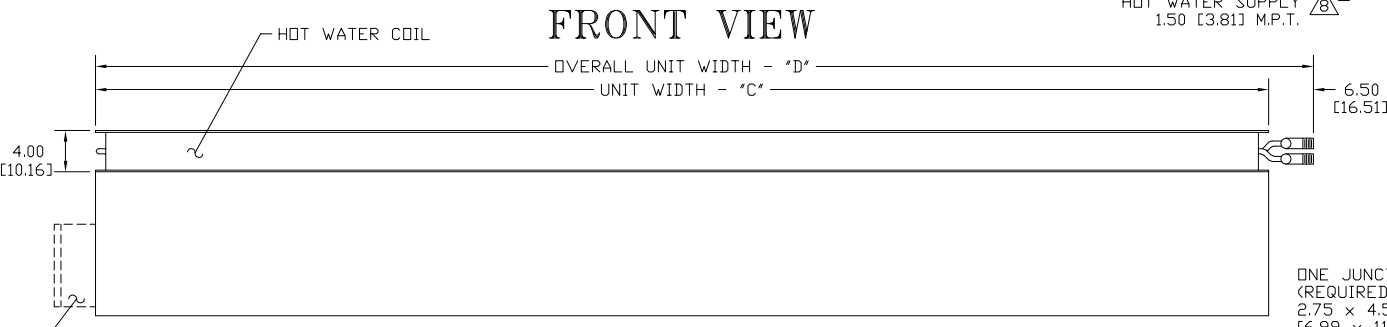
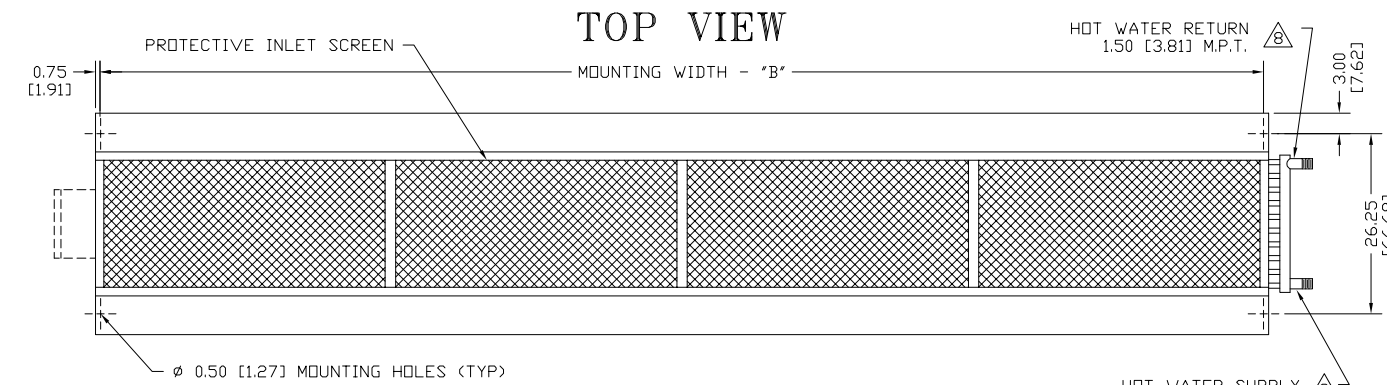

ONE JUNCTION BOX PER MOTOR
(REQUIRED FOR REMOTE PANEL)
2.75 x 4.50 x 2.00
[6.99 x 11.43 x 5.08]
L.H. STD.; R.H. OPTIONAL

NOTES:

- 1 AIR CURTAIN MUST BE INSTALLED SO AIR STREAM IS NOT OBSTRUCTED WHEN DEFLECTED 20° TO EITHER SIDE OF \bar{C} .
- 2 ELECTRICAL CONNECTIONS TO BE FLEXIBLE.
- 3 FIELD VERIFY DIMENSIONS.
- 4 ANCHORS TO SUPPORTING STRUCTURE BY OTHERS.
- 5 ADEQUACY OF SUPPORTING STRUCTURE IS TO BE VERIFIED BY A PROFESSIONAL STRUCTURAL ENGINEER.
- 6 LETTER "W" IN MODEL NUMBER DESIGNATES, HOT WATER HEATED UNIT. THE "T" DESIGNATES TOP INTAKE.
- 7 OPTIONAL CONTROL PANEL AVAILABLE: LEFT HAND MOUNT, RIGHT HAND MOUNT, OR REMOTE. PLEASE SPECIFY.
- 8 COIL CONNECTIONS AS SHOWN, OPPOSITE AND SAME END CONNECTIONS AVAILABLE, PLEASE SPECIFY.
- 9 DIMENSIONS IN INCHES [CENTIMETERS].

MODEL	NOZZLE WIDTH "A"	MOUNTING WIDTH "B"	UNIT WIDTH "C"	OVERALL WIDTH "D"
IDC16-1060W-T	60.00 [152.40]	61.50 [156.21]	63.00 [160.02]	69.50 [176.53]
IDC16-1072W-T	72.00 [182.88]	73.50 [186.69]	75.00 [190.50]	81.50 [207.01]
IDC16-1084W-T	84.00 [213.36]	85.50 [217.17]	87.00 [220.98]	93.50 [237.49]
IDC16-1096W-T	96.00 [243.84]	97.50 [247.65]	99.00 [251.46]	105.50 [267.97]
IDC16-1108W-T	108.00 [274.32]	109.50 [278.13]	111.00 [281.94]	117.50 [298.45]
IDC16-1120W-T	117.00 [297.18]	118.50 [300.99]	120.00 [304.80]	126.50 [321.31]
IDC16-1132W-T	132.00 [335.28]	133.50 [339.09]	135.00 [342.90]	141.50 [359.41]
IDC16-1144W-T	144.00 [365.76]	145.50 [369.57]	147.00 [373.38]	153.50 [389.89]
IDC16-1156W-T	156.00 [396.24]	157.50 [400.05]	159.00 [403.86]	165.50 [420.37]
IDC16-2168W-T	168.00 [426.72]	169.50 [430.53]	171.00 [434.34]	177.50 [450.85]
IDC16-2180W-T	180.00 [457.20]	181.50 [461.01]	183.00 [464.82]	189.50 [481.33]
IDC16-2192W-T	192.00 [487.68]	193.50 [491.49]	195.00 [495.30]	201.50 [511.81]

PROJECT		TITLE: BERNER
LOCATION		MODEL IDC16 AIR CURTAIN
ARCHITECT		TOP INTAKE - HOT WATER HEATED SYSTEM
ENGINEER		
DWG. NO.	IDC16-WTR1	
DATE	02JUNE14	
BY	S. Beil	
REPLACES	-	
BY	-	BERNER INTERNATIONAL CORP. NEW CASTLE, PA.

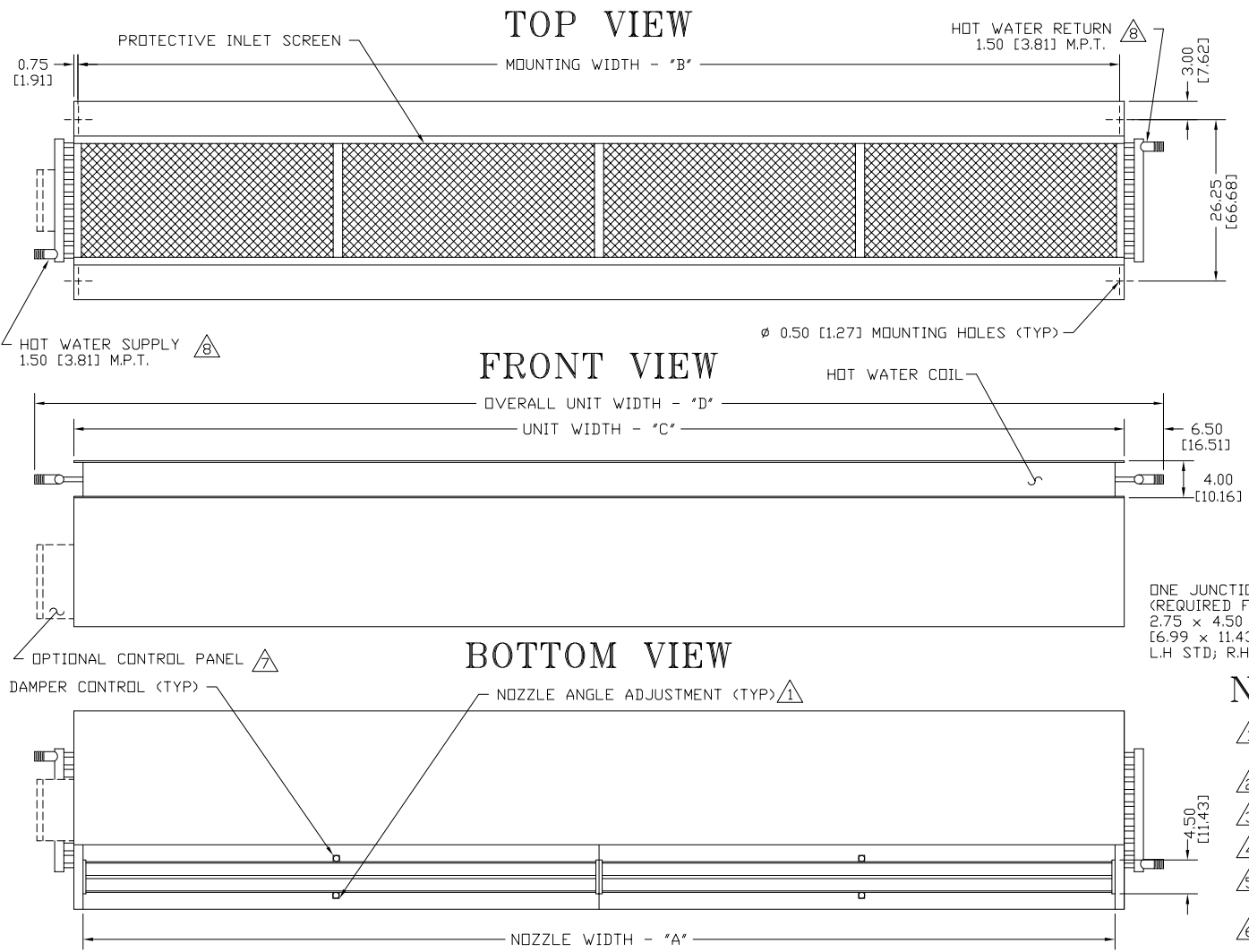

IDC16®

HOT WATER HEATED TOP INTAKE

OPP. END SUP./RET.

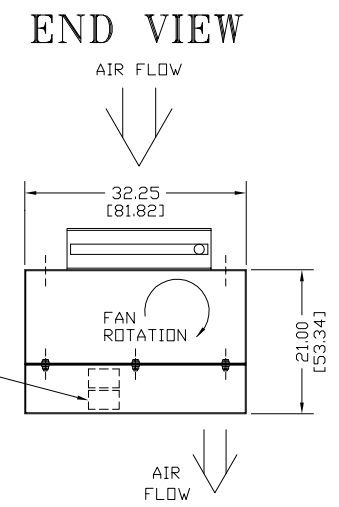

ONE JUNCTION BOX PER MOTOR
(REQUIRED FOR REMOTE PANEL)
2.75 x 4.50 x 2.00
[6.99 x 11.43 x 5.08]
L.H. STD; R.H. OPTIONAL

NOTES:

- 1 AIR CURTAIN MUST BE INSTALLED SO AIR STREAM IS NOT OBSTRUCTED WHEN DEFLECTED 20° TO EITHER SIDE OF C.
- 2 ELECTRICAL CONNECTIONS TO BE FLEXIBLE.
- 3 FIELD VERIFY DIMENSIONS.
- 4 ANCHORS TO SUPPORTING STRUCTURE BY OTHERS.
- 5 ADEQUACY OF SUPPORTING STRUCTURE IS TO BE VERIFIED BY A PROFESSIONAL STRUCTURAL ENGINEER.
- 6 LETTER "W" IN MODEL NUMBER DESIGNATES, HOT WATER HEATED UNIT. THE "T" DESIGNATES TOP INTAKE.
- 7 OPTIONAL CONTROL PANEL AVAILABLE: LEFT HAND MOUNT, RIGHT HAND MOUNT, OR REMOTE. PLEASE SPECIFY.
- 8 COIL CONNECTIONS AS SHOWN, OPPOSITE AND SAME END CONNECTIONS AVAILABLE, PLEASE SPECIFY.
- 9 DIMENSIONS IN INCHES [CENTIMETERS].

MODEL	NOZZLE WIDTH "A"	MOUNTING WIDTH "B"	UNIT WIDTH "C"	OVERALL WIDTH "D"
IDC16-1060W-T	60.00 [152.40]	61.50 [156.21]	63.00 [160.02]	76.00 [193.04]
IDC16-1072W-T	72.00 [182.88]	73.50 [186.69]	75.00 [190.50]	88.00 [223.52]
IDC16-1084W-T	84.00 [213.36]	85.50 [217.17]	87.00 [220.98]	100.00 [254.00]
IDC16-1096W-T	96.00 [243.84]	97.50 [247.65]	99.00 [251.46]	112.00 [284.48]
IDC16-1108W-T	108.00 [274.32]	109.50 [278.13]	111.00 [281.94]	124.00 [314.96]
IDC16-1120W-T	117.00 [297.18]	118.50 [300.99]	120.00 [304.80]	133.00 [337.82]
IDC16-1132W-T	132.00 [335.28]	133.50 [339.09]	135.00 [342.90]	148.00 [375.92]
IDC16-1144W-T	144.00 [365.76]	145.50 [369.57]	147.00 [373.38]	160.00 [406.40]
IDC16-1156W-T	156.00 [396.24]	157.50 [400.05]	159.00 [403.86]	172.00 [436.88]
IDC16-2168W-T	168.00 [426.72]	169.50 [430.53]	171.00 [434.34]	184.00 [467.36]
IDC16-2180W-T	180.00 [457.20]	181.50 [461.01]	183.00 [464.82]	196.00 [497.84]
IDC16-2192W-T	192.00 [487.68]	193.50 [491.49]	195.00 [495.30]	208.00 [528.32]

PROJECT		TITLE: BERNER
LOCATION		MODEL IDC16 AIR CURTAIN
ARCHITECT		TOP INTAKE - HOT WATER HEATED SYSTEM
ENGINEER		
DWG. NO.	IDC16-WTR2	
DATE	02JUNE14	
BY	S. Beil	
REPLACES	-	
BY	-	BERNER INTERNATIONAL CORP. NEW CASTLE, PA.

TOP VIEW

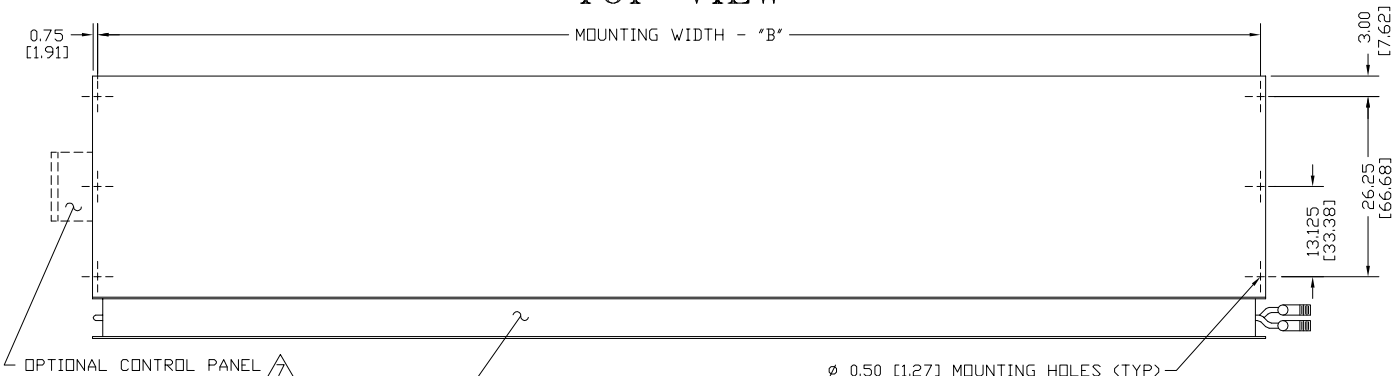

IDC16 HOT WATER HEATED FRONT INTAKE SAME END SUP./RET.

FRONT VIEW

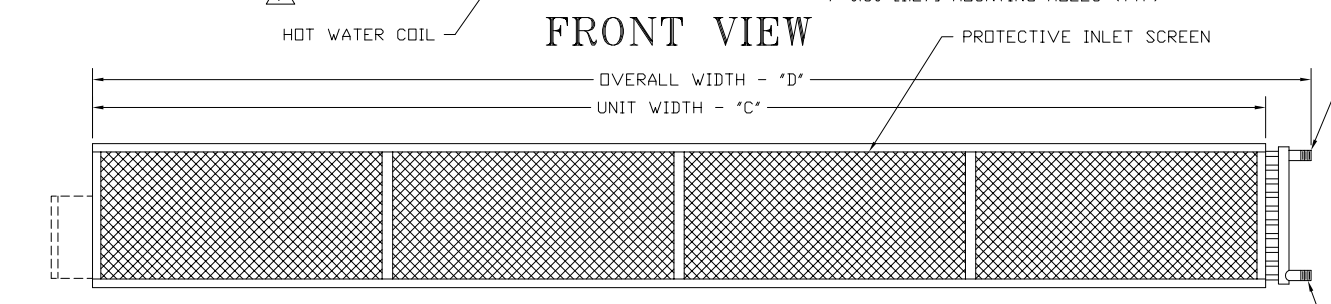

BOTTOM VIEW

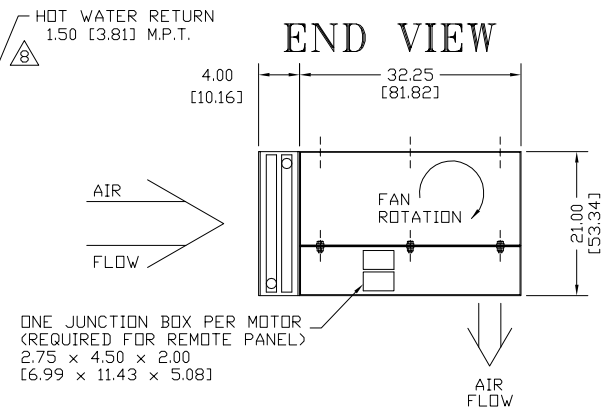
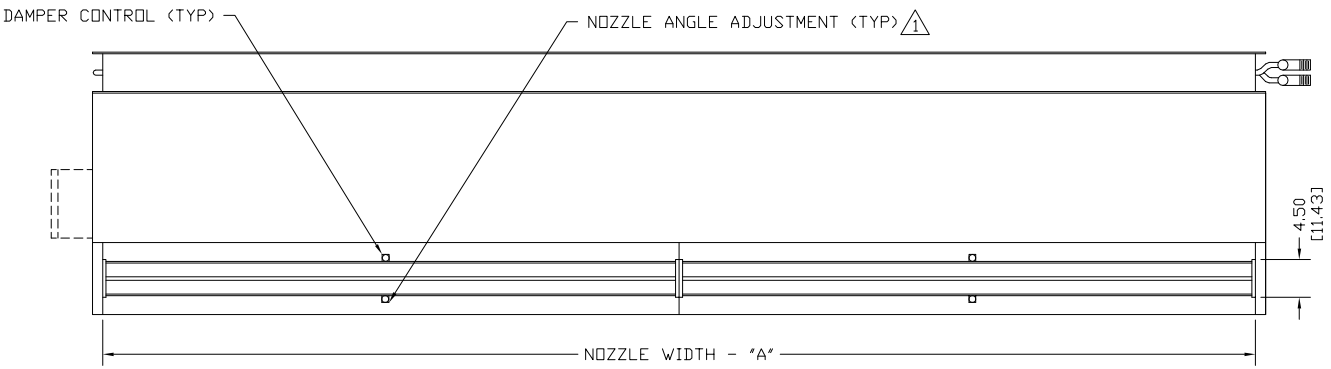

ONE JUNCTION BOX PER MOTOR
(REQUIRED FOR REMOTE PANEL)
2.75 x 4.50 x 2.00
[6.99 x 11.43 x 5.08]

NOTES:

- 1 AIR CURTAIN MUST BE INSTALLED SO AIR STREAM IS NOT OBSTRUCTED WHEN DEFLECTED 20° TO EITHER SIDE OF C.
- 2 ELECTRICAL CONNECTIONS TO BE FLEXIBLE.
- 3 FIELD VERIFY DIMENSIONS.
- 4 ANCHORS TO SUPPORTING STRUCTURE BY OTHERS.
- 5 ADEQUACY OF SUPPORTING STRUCTURE IS TO BE VERIFIED BY A PROFESSIONAL STRUCTURAL ENGINEER.
- 6 LETTER "W" IN MODEL NUMBER DESIGNATES, HOT WATER HEATED UNIT. THE "F" DESIGNATES FRONT INTAKE.
- 7 OPTIONAL CONTROL PANEL AVAILABLE: LEFT HAND MOUNT, RIGHT HAND MOUNT, OR REMOTE. PLEASE SPECIFY.
- 8 COIL CONNECTIONS AS SHOWN, OPPOSITE AND SAME END CONNECTIONS AVAILABLE, PLEASE SPECIFY.
- 9 DIMENSIONS IN INCHES [CENTIMETERS].

MODEL	NOZZLE WIDTH 'A'	MOUNTING WIDTH 'B'	UNIT WIDTH 'C'	OVERALL WIDTH 'D'
IDC16-1060W-F	60.00 [152.40]	61.50 [156.21]	63.00 [160.02]	69.50 [176.53]
IDC16-1072W-F	72.00 [182.88]	73.50 [186.69]	75.00 [190.50]	81.50 [207.01]
IDC16-1084W-F	84.00 [213.36]	85.50 [217.17]	87.00 [220.98]	93.50 [237.49]
IDC16-1096W-F	96.00 [243.84]	97.50 [247.65]	99.00 [251.46]	105.50 [267.97]
IDC16-1108W-F	108.00 [274.32]	109.50 [278.13]	111.00 [281.94]	117.50 [298.45]
IDC16-1120W-F	117.00 [297.18]	118.50 [300.99]	120.00 [304.80]	126.50 [321.31]
IDC16-1132W-F	132.00 [335.28]	133.50 [339.09]	135.00 [342.90]	141.50 [359.41]
IDC16-1144W-F	144.00 [365.76]	145.50 [369.57]	147.00 [373.38]	153.50 [389.89]
IDC16-1156W-F	156.00 [396.24]	157.50 [400.05]	159.00 [403.86]	165.50 [420.37]
IDC16-2168W-F	168.00 [426.72]	169.50 [430.53]	171.00 [434.34]	177.50 [450.85]
IDC16-2180W-F	180.00 [457.20]	181.50 [461.01]	183.00 [464.82]	189.50 [481.33]
IDC16-2192W-F	192.00 [487.68]	193.50 [491.49]	195.00 [495.30]	201.50 [511.81]

PROJECT		TITLE: BERNER MODEL IDC16 AIR CURTAIN FRONT INTAKE - HOT WATER HEATED SYSTEM
LOCATION		
ARCHITECT		
ENGINEER		
DWG. NO.	IDC16-WTR3	REPLACES - BY -
DATE	02JUNE14	
BY	S. Beil	BERNER INTERNATIONAL CORP. NEW CASTLE, PA.
REPLACES	-	
BY	-	

TOP VIEW

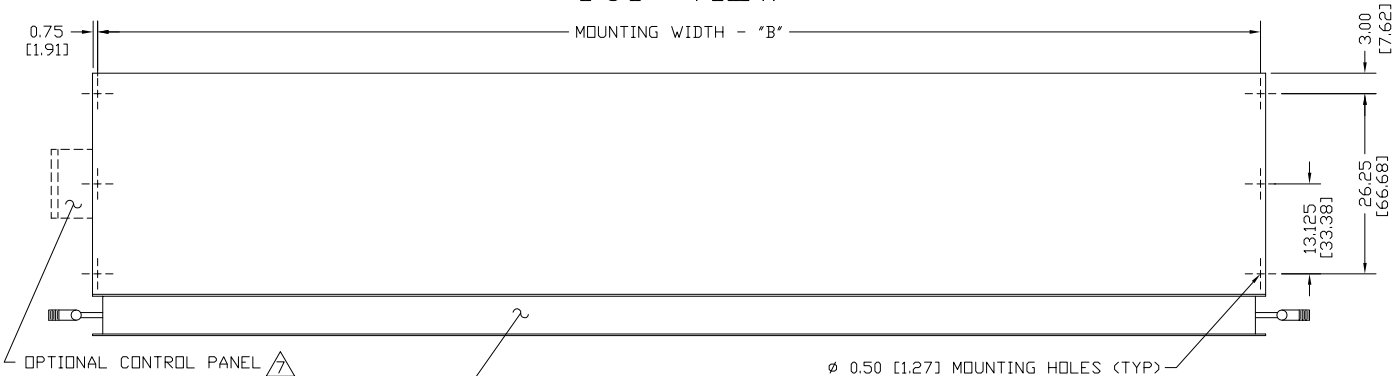

FRONT VIEW

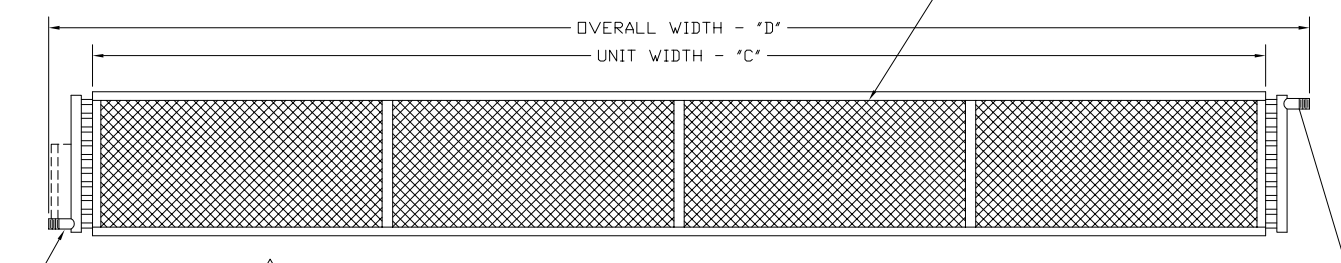

BOTTOM VIEW

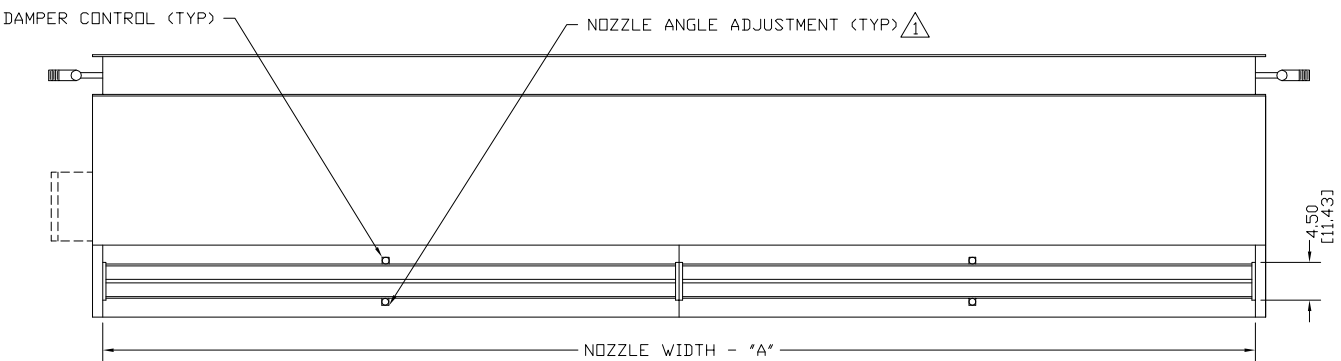

MODEL	NOZZLE WIDTH "A"	MOUNTING WIDTH "B"	UNIT WIDTH "C"	OVERALL WIDTH "D"
IDC16-1060W-F	60.00 [152.40]	61.50 [156.21]	63.00 [160.02]	76.00 [193.04]
IDC16-1072W-F	72.00 [182.88]	73.50 [186.69]	75.00 [190.50]	88.00 [223.52]
IDC16-1084W-F	84.00 [213.36]	85.50 [217.17]	87.00 [220.98]	100.00 [254.00]
IDC16-1096W-F	96.00 [243.84]	97.50 [247.65]	99.00 [251.46]	112.00 [284.48]
IDC16-1108W-F	108.00 [274.32]	109.50 [278.13]	111.00 [281.94]	124.00 [314.96]
IDC16-1120W-F	117.00 [297.18]	118.50 [300.99]	120.00 [304.80]	133.00 [337.82]
IDC16-1132W-F	132.00 [335.28]	133.50 [339.09]	135.00 [342.90]	148.00 [375.92]
IDC16-1144W-F	144.00 [365.76]	145.50 [369.57]	147.00 [373.38]	160.00 [406.40]
IDC16-1156W-F	156.00 [396.24]	157.50 [400.05]	159.00 [403.86]	172.00 [436.88]
IDC16-2168W-F	168.00 [426.72]	169.50 [430.53]	171.00 [434.34]	184.00 [467.36]
IDC16-2180W-F	180.00 [457.20]	181.50 [461.01]	183.00 [464.82]	196.00 [497.84]
IDC16-2192W-F	192.00 [487.68]	193.50 [491.49]	195.00 [495.30]	208.00 [528.32]

IDC16

HOT WATER HEATED FRONT INTAKE

OPP. END SUP./RET.

END VIEW

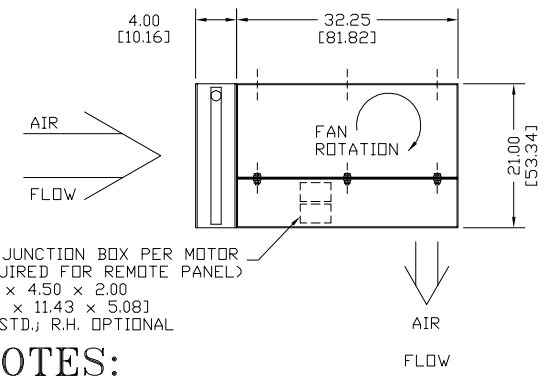

ONE JUNCTION BOX PER MOTOR (REQUIRED FOR REMOTE PANEL)
 2.75 x 4.50 x 2.00
 [6.99 x 11.43 x 5.08]
 L.H. STD.; R.H. OPTIONAL

NOTES:

- 1 AIR CURTAIN MUST BE INSTALLED SO AIR STREAM IS NOT OBSTRUCTED WHEN DEFLECTED 20° TO EITHER SIDE OF C.
- 2 ELECTRICAL CONNECTIONS TO BE FLEXIBLE.
- 3 FIELD VERIFY DIMENSIONS.
- 4 ANCHORS TO SUPPORTING STRUCTURE BY OTHERS.
- 5 ADEQUACY OF SUPPORTING STRUCTURE IS TO BE VERIFIED BY A PROFESSIONAL STRUCTURAL ENGINEER.
- 6 LETTER "W" IN MODEL NUMBER DESIGNATES, HOT WATER HEATED UNIT. THE "F" DESIGNATES FRONT INTAKE.
- 7 OPTIONAL CONTROL PANEL AVAILABLE: LEFT HAND MOUNT, RIGHT HAND MOUNT, OR REMOTE. PLEASE SPECIFY.
- 8 COIL CONNECTIONS AS SHOWN, OPPOSITE AND SAME END CONNECTIONS AVAILABLE, PLEASE SPECIFY.
- 9 DIMENSIONS IN INCHES (CENTIMETERS).

PROJECT	
LOCATION	
ARCHITECT	
ENGINEER	
DWG. NO.	IDC16-WTR4
DATE	02JUNE14
BY	S. Beil
REPLACES	-
BY	-
TITLE:	BERNER MODEL IDC16 AIR CURTAIN FRONT INTAKE - HOT WATER HEATED SYSTEM
	BERNER INTERNATIONAL CORP. NEW CASTLE, PA.