



www.Berner.com

Architectural Recessed Air Curtain Series #ARD12 & ARC16

WHEN THE DOORS ARE OPEN™ save energy & create healthy, comfortable environments



Installation & Maintenance Instructions

TABLE OF CONTENTS

I. UNCRATING.....	2
II. MOUNTING PREPARATION.....	3
III. MOUNTING	3
IV. ELECTRICAL CONNECTIONS.....	4
V. FIELD CONNECTIONS.....	6
VI. OPERATING INSTRUCTIONS	6
INTELLISWITCH™	
QUICK START OPERATION	10
FAQ's (FREQUENTLY ASKED QUESTIONS).....	12
VII. MAINTENANCE AND CLEANING.....	7
VIII. SERVICE.....	8
IX. TROUBLESHOOTING.....	14
X. APPENDIX	
A. SERIAL NETWORK CONNECTION.....	15
B. REMOTE MOUNTED DISPLAY FACEPLATE.....	15
C. INFRA-RED REMOTE CONTROL.....	15
D. BACnet-IP INTEGRATION	15
XI. WARRANTY	16

Thank you for choosing Berner.

Berner International has been saving energy and creating healthy, comfortable environments for our customers for over 60 years. Berner offers unmatched quality, performance, and dependability—not to mention our service. At Berner, we stand behind our products.



READ ALL INSTRUCTIONS BEFORE INSTALLING OR USING AIR CURTAIN

II-300
October, 2024

WARNING: TO REDUCE THE RISK OF FIRE, ELECTRIC SHOCK OR INJURY TO PERSONS, OBSERVE THE FOLLOWING:

- A. Read all instructions before installing or using this air curtain.
- B. Use this unit only in the manner intended by the manufacturer and described in this manual. Any other use not recommended by the manufacturer may cause fire, electric shock, or injury to persons. If you have any questions, contact the manufacturer.
- C. Before servicing or cleaning unit, switch power off at service panel and lock the service disconnecting means to prevent power from being switched on accidentally. When the service disconnecting means cannot be locked, securely fasten a prominent warning device, such as a tag, to the service panel.
- D. Installation work and electrical wiring must be done by qualified person(s) in accordance with all applicable national and local codes having jurisdiction, including fire-rated construction. See page 5, ELECTRICAL CONNECTIONS (NEC Code ANSI/NFPA No. 70).
- E. When cutting or drilling into wall or ceiling, do not damage electrical wiring and other hidden utilities.
- F. To reduce the risk of fire, do not store or use gasoline or other flammable vapors and liquids in the vicinity of the air curtain.
- G. This air curtain is hot when in use. To avoid burns, do not let bare skin touch hot surfaces. Keep combustible materials, such as furniture, pillows, bedding, papers, clothes, etc. and curtains at least 1 inch from the top, back, front, sides and at least 6 feet from the discharge of the air curtain.
- H. Extreme caution is necessary when any air curtain is used by or near children or invalids, and whenever the heater is left operating unattended.
- I. Do not operate any air curtain after it malfunctions. Disconnect power at the service panel and have the air curtain inspected by a reputable electrician before reusing.
- J. To disconnect the air curtain, turn controls to "off", and turn off power to the air curtain circuit at main disconnect panel.
- K. Do not insert or allow foreign objects to enter any ventilation or discharge opening as this may cause an electric shock or fire, or damage the air curtain.
- L. To prevent a possible fire, do not block the air intake or discharge of the air curtain in any manner.
- M. The air curtain has hot and arcing or sparking parts inside. Do not use it in areas where gasoline, paint, or flammable vapors or liquids are used or stored.
- N. This heater may include an audible or visual alarm to warn that parts of the heater are getting excessively hot. If the alarm sounds (or illuminates), immediately turn the heater off and inspect for any objects on or adjacent to the heater that may have blocked the airflow or otherwise caused high temperatures to have occurred. DO NOT OPERATE THE HEATER WITH THE ALARM SOUNDING (OR ILLUMINATING).



Model: ARD12

For mounting heights up to 12'



Model: ARC16

For mounting heights up to 16'

I. UNCRATING

Carefully examine the carton(s) for damage. If the carton is damaged, immediately notify the shipping company. **Do not delay in filing claim.** If the air curtain(s) were shipped on wooden skids, remove protective wood and banding straps securing the carton(s) to the skid. Open the carton(s) and remove all protective packaging. Immediately verify that the electrical rating nameplate located on the cover matches electrical power supply available. Retain the shipping carton(s) until the air curtain(s) are installed and properly operating.

ACCESSORIES: If the air curtain(s) were ordered with optional electrical accessories, the accessories will be found in the carton containing the air curtain packed in a red bag (marked "additional parts inside") or in a separate carton(s) accompanying the air curtain(s).

Check all of the cartons/skids for accessories before discarding.

II. MOUNTING PREPARATION

INDOOR MOUNTING ONLY - Environmental/Insect/Dust Control

- A. The Architectural Recessed 12/16 air curtain is designed to be an effective barrier against cold drafts in the winter and hot air in the summer. To achieve optimum protection, the unit should be mounted on the inside of the building, flush with the ceiling, so that the airstream can pass as close to the top of the door opening as possible. To ensure peak performance keep the air stream free of obstructions.
- B. **The air curtain will not perform properly if negative air pressure exists in the building. Under these conditions, a means for makeup air to the building must be provided so that the air pressure on both sides of the opening is in balance.**
- C. Before mounting the air curtain, check the supporting structure to verify that it has sufficient load-carrying capacity to support the weight of the unit(s). The mounting hardware (supplied by others) should be capable of supporting a minimum of three (3) times the weight of the unit.
See Weight Charts Table 1
- D. When determining the mounting location for the unit(s), make sure that nothing interferes with the curtain of air developed when the discharge vanes are directed from 0° to 20° toward the door opening. If the air stream strikes any obstruction (the top edge of the doorway, a door opening device, etc.), the effectiveness of the unit will be greatly reduced. **See Figure 1.**
- E. For optimum performance, the bottom of the discharge nozzle should be located in such a manner that it is spaced out from the wall 3/8" for every inch the unit is above the door opening.
- F. Electric heated unit(s) shall:
1. Have a minimum clearance of at least 6' between the bottom of the unit and the floor.
 2. Be installed Indoors Only.
 3. The unit is shipped without the front and back trim installed to protect it from shipping damage. This trim need not be installed until after the unit is hung. **See Figure 2.**

III. MOUNTING INSTRUCTIONS (General)

- A. The Architectural Recessed 12/16 series air curtain enclosure is equipped with four 5/16"-18 threaded inserts on the top of the unit for suspended mounting. **See Figure 3.**

For lighter lifting the blower assembly may be removed so that the enclosure can be easily installed. See Section VIII: SERVICE for instruction on removing the blower assembly.

- B. The electrical junction box(s) is located on the outside of the enclosure on the left side (standard) of the unit.
- C. Determine the exact mounting location of the air curtain unit.
- D. Create structural attachment points to suspend the unit above the ceiling so that the unit is centered and parallel with the door opening.

Model	TOTAL NET WEIGHT		
	Ambient	Electric Heat	Steam/Hot Water Heat
ARD12-1036	101	105	134
ARD12-1042	108	112	144
ARD12-1048	114	118	153
ARD12-1060	134	138	182
ARD12-2060	171	179	219
ARD12-2072	182	190	234
ARD12-2084	194	202	252
ARD12-2096	205	213	269
ARD12-3096	245	257	309
ARD12-2108	223	231	292
ARD12-3108	273	285	342
ARD12-2120	241	249	315
ARD12-3120	285	297	359
ARD12-3132	297	309	380
ARD12-3144	308	320	397
ARD12-4144	364	380	453

Model	TOTAL NET WEIGHT		
	Ambient	Electric Heat	Steam/Hot Water Heat
ARC16-1036	104	108	141
ARC16-1042	111	115	151
ARC16-1048	117	121	160
ARC16-1060	137	141	187
ARC16-2060	177	185	227
ARC16-2072	187	195	243
ARC16-2084	200	208	262
ARC16-2096	211	219	279
ARC16-3096	253	265	321
ARC16-2108	229	237	302
ARC16-3108	281	293	354
ARC16-2120	247	255	325
ARC16-3120	293	305	371
ARC16-3132	305	317	392
ARC16-3144	316	328	409
ARC16-4144	374	390	467

TABLE 1 - Weight Charts

- E. Suspend air curtain cabinet by attaching threaded rods to the unit and support structures. Adjust unit position so the bottom of the cabinet is flush with the underside of the ceiling.
 - F. Install the front and back trim using the provided fasteners.
See Figure 3.
 - G. Finish off ceiling edge as required.
- NOTE: Finishing materials must not overlap the bottom of the cabinet to allow the intake screen to open freely.**
- H. If the blower assembly was removed, re-install it along with nozzle surround and bottom access cover.

IV. ELECTRICAL CONNECTIONS

All electrical wiring and connections **MUST** be performed by qualified personnel in accordance with the latest edition of the National Electrical Code ANSI/NFPA No. 70 or, in Canada, the Canadian Electrical Code, Part 1-C.S.A. Standard C22.1 and local codes and regulations.

- A. Check the rating nameplate on the unit for supply voltage and current requirements. A separate line voltage supply with a suitable branch circuit protection device should be run directly from the main electrical panel to the unit. A disconnect switch for each branch circuit is a required part of this installation. See the voltage label on the unit for circuiting and total electrical load.
- B. All field wiring must be copper with a minimum insulation of 60°C within approved conduit. If any of the wire supplied with the unit must be replaced, it must be replaced with copper wiring with a minimum insulation of 90°C.
- C. Electric, steam and hot water heated air curtains are factory equipped with an air curtain mounted solid state temperature sensor cable located in the j-box. Depending on where the temperature is to be measured, the sensor may be left on the end plate or positioned elsewhere. Do not put any clamps on the rubber coated tip.
- D. Remove the junction box cover.
- E. Connect all supply and control circuit wires according to the wiring diagram provided.

NOTE: For Electric heated air curtains provided with the optional remote thermostat, mount and wire the thermostat according to thermostat instructions and wiring diagram.

- F. Serial Network Connection, if two or more air curtains are to be linked together for Serial Network operation, continue, otherwise, skip to Step G.

NOTE: The air curtain must have been ordered from the factory with this option.

NOTE: One Intelliswitch™ serial cable assembly (part # 505SC*INT485-A) is required for every air curtain that is to be used as a Serial Network Connection.**
***** denotes length of cable in feet "008" = 8 ft. long.**

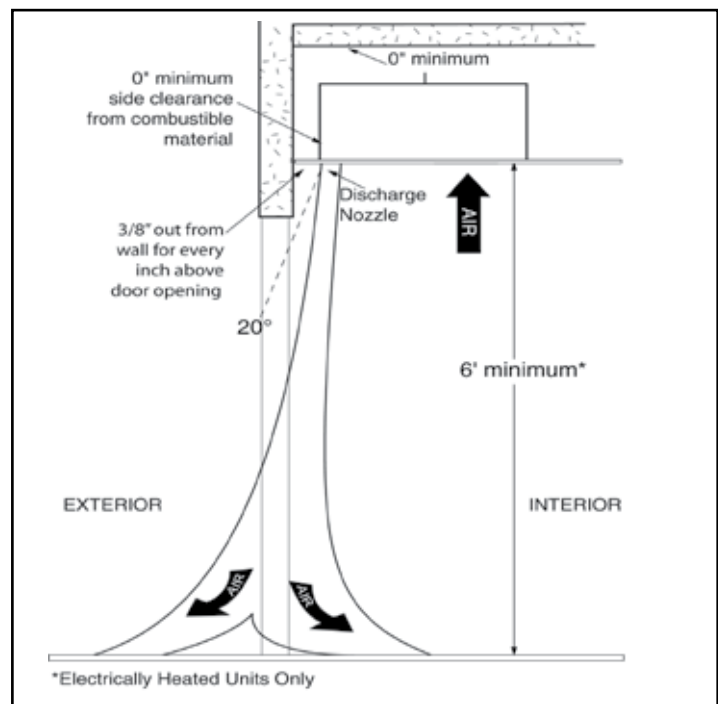

Figure 1 - General Mounting

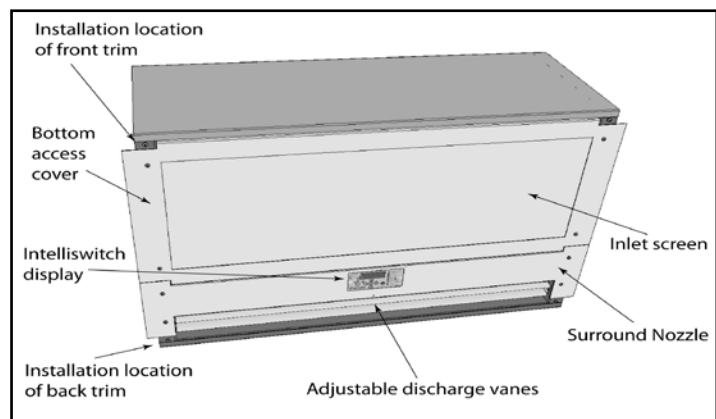

Figure 2

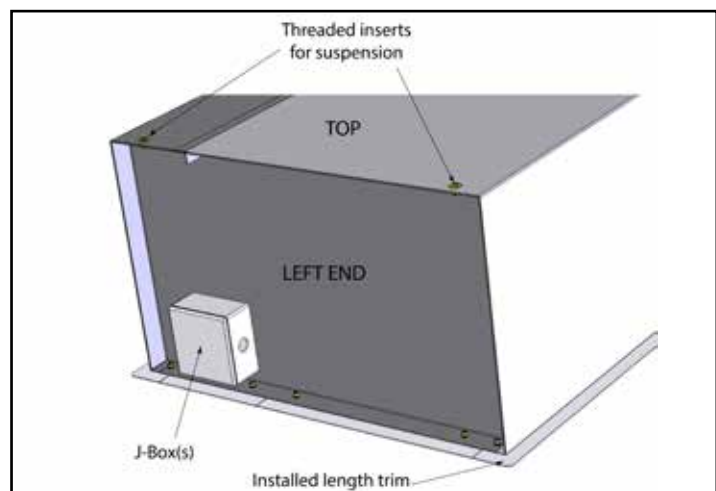

Figure 3

For Serial Network operation, a serial cable connection must be made between the Intelliswitch™ control boards of each air curtain to be linked.

1. Disconnect power to all the air curtains
2. Find the (RS485) phone jack couplers protruding through the hole in the endplate next to the j-box.
3. The serial cable ordered for each air curtain will be coiled up and attached to the left end plate.

NOTE: There will be one less serial cable than the number of air curtains ordered. E.g. Two air curtains together will need only one cable; three air curtains together will need two cables, etc. Any extra cables can be kept as spares.

4. Plug the (RS485) male phone jack on the end of the serial cable into the empty coupler on the next air curtain.
5. Continue process for all air curtains that are to be connected serially.
6. Serial cable connections are capable of two way communication. It does not matter to which coupler the cables are connected.
7. The first and last air curtain in the group will each have an empty coupler after all connections are made. If there are only two air curtains connected, each will have an empty cable coupler.

NOTE: If a longer cable is required than was supplied, it can be ordered from the factory or made by using standard 4 wire flat telephone cable, phone jack connectors and the proper crimping tool.

- G. Remote Mounted Display Faceplate – If operation of the Intelliswitch® is to be through a Factory Ordered Remote Mounted Display Faceplate, continue, otherwise, skip to step H.

NOTE: Maximum mounting distance between the Display Faceplate and the air curtain is 20'.

1. When the remote faceplate option is ordered from the factory, the air curtain comes equipped with the blank faceplate already installed and the 20' ribbon cable attached. The Display Faceplate is shipped loose, ready for field installation.
2. Locate the male end of the conductor ribbon cable and run it to the remote display location. The cable is minimum CL2 rated and should not need to be in conduit.
3. Connect the female end of the ribbon cable to the 14-pin socket on the back of the display board with the cable approaching from the top and the red ribbon indicator to the right (when facing the front of the display board).
4. Mount Display Faceplate to the wall.

- H. For Electric, Steam and Hot Water air curtains proceed to **Section V - Field Connections** otherwise proceed to **Section VI - Airflow Adjustments**

V. FIELD CONNECTIONS

A. ELECTRICALLY HEATED MODELS

The heater circuit may be controlled by a remote thermostat or manually through the Intelliswitch® located on the discharge side of the air curtain. Overheating protection is provided by auto reset thermal cutouts built into the heater coil assembly (see the wiring diagram).

B. STEAM AND HOT WATER HEATED MODELS

Piping should be done in accordance with local codes, regulations and standard practices. Connect the building system supply and return to the 3/4" MPT nipples on the heating coil. **See Figure 4.**

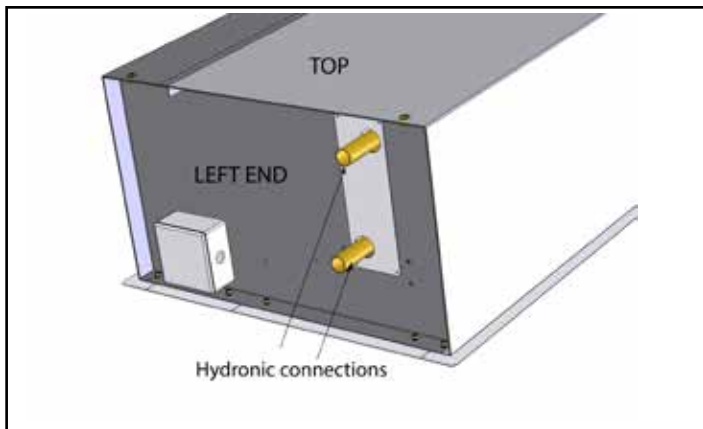

Figure 4 - Steam / Hot Water Connections

VI. OPERATING INSTRUCTIONS

This air curtain comes with a built-in Berner Intelliswitch™ Digital Controller to operate the fan activation, fan speed selection, and heat activation. The air curtain must be properly installed before it is used.

1. For detailed instructions on how to operate the Intelliswitch™ and select from a list of standard modes of control, proceed to the following pages:
Quick Start Operation Guide, page 8
Frequently Asked Questions (FAQs), page 10
NOTE: For a Detailed Programming Guide, go to www.Berner.com/Intelliswitch
2. Unheated units will have the fans activated by a door switch or sensor. The unit speed can be selected from the Intelliswitch™ display.
3. Heated units will have fans activated by a door switch or sensor, but may also be activated by the thermostat in Comfort Plus Mode. The unit speed can be selected from the Intelliswitch display.
4. To operate using the Berner AIR™ App and/or BACnet-IP, download the app and follow the prompts. For operation using BACnet-IP, after pairing the air curtain to the app, go into the settings menu and select the BACnet option. Follow the prompts to configure the BACnet controller.

NOTE: The air curtain must have been ordered from the factory with the Berner AIR (smart controller & app) to use these options.

The Berner AIR™ App allows air curtain(s) to be programmed & operated via smart phone and via the BACnet-IP communication protocol. Requires on-site, secure wi-fi connection(provided by others).



Berner recommends having the on-site user(s) set-up the Berner AIR™ App on his/her smart phone.

If ordered with the Berner AIR™

**Connect with
BERNER AIR**

- ▶ SET UP
- ▶ CONTROL
- ▶ TROUBLESHOOT

BERNER.COM

B. AIR STREAM ADJUSTMENT

1. With the air curtain operating and the door in its full open position, check to see that nothing is obstructing the airflow at the discharge nozzle vanes.
2. Find the air stream split location. Hold a handkerchief by its corners, approximately 12" above the floor. Gently move the handkerchief back and forth in the doorway. Make sure the air is being directed to both the inside and the outside. **See Figure 5.** The split location is indicated where the handkerchief is vertical with minimal or no fluttering.
3. The split location should be approximately 3" outside the doorway. If necessary adjust the discharge nozzle vanes by de-energizing the unit, loosening the nozzle vane locking screws and adjusting vanes.

VII. MAINTENANCE & CLEANING

CAUTION: ELECTRIC SHOCK HAZARD Disconnect power whenever servicing unit. More than one disconnect may be required to de-energize unit.

Keep your air curtain operating at peak efficiency by cleaning the blower wheels, motor(s) and intake grille. Buildup of dust on the blower wheels can cause vibration, noise and excessive wear on the motor bearings. The frequency of cleaning will depend on the environment where the unit is operating.

Dirty, dusty or greasy environments could require a cleaning schedule of once every two months. Otherwise, the unit(s) should be scheduled for cleaning a minimum of once every (6) months. To access the interior of the unit:

- A. Disconnect and lockout power to the unit. If necessary remove the blower assembly. **See Section VIII SERVICE** for instructions on how to remove blower module.
- B. Remove the bottom access cover by removing (2) Phillips head machine screws located at the cover's corners. **See Figure 6.**
- C. Vacuum and scrape (if necessary) to remove the buildup of dirt and debris from the interior of the air curtain. The motor(s) are permanently lubricated and require no additional lubrication.
- D. Pull the filter out from underneath the struts of the bottom access cover. It is easiest to work from the middle, pulling one side out and then the other. Spray the filter with warm, soapy water, rinse, and pad dry.
- E. Replace Filter.
- F. Reinstall the bottom access cover.
- G. Switch the power on after cleaning.

CAUTION: STAND CLEAR of the unit or wear safety goggles as loose debris may be present and may exit the nozzle.

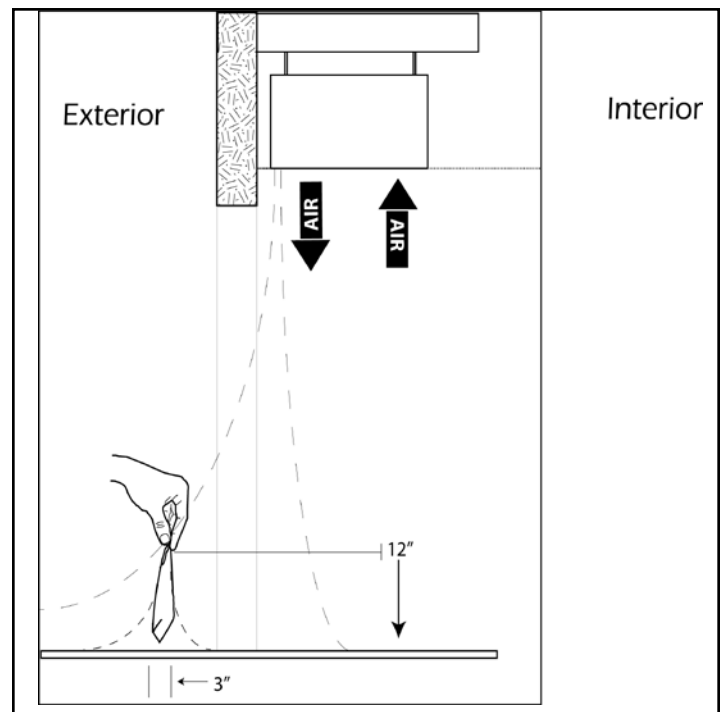

Figure 5 - Air Stream Adjustment

VIII. SERVICE

CAUTION: ELECTRIC SHOCK HAZARD Disconnect power whenever servicing unit. More than one disconnect may be required to de-energize unit.

Any service performed on the ARCHITECTURAL Recessed Series air curtain **MUST** be done by qualified personnel.

Berner air curtains require very little servicing. All parts are easily accessible for periodic inspection and maintenance. Units should be cleaned at least twice a year. Your particular application (the amount of dirt and dust in the air) and location of the unit(s) will determine how often your unit(s) will need to be cleaned and serviced. All motors have permanently lubricated, sealed, sleeve bearings and require no maintenance.

A. To remove the blower module and clean or replace the fans and motor:

1. Disconnect and lockout power to the unit.
2. Remove the bottom access cover by removing (4) Phillips head machine screws located at the cover's corners. **See Figure 6.**
3. If desired, the nozzle surround may be removed to provide more working room. To remove the nozzle surround, remove the (4) Phillips head machine screws from the corners. The Intelliswitch® ribbon cable must also be disconnected from the back of the display circuit board before the nozzle surround can be set aside.
4. Disconnect motor power wires/harness from motor.
5. If the unit has electric heat, the heaters need to be disconnected from supply wiring. Each fan housing will have a heating element on both of its sides, spanning the inlet venturi. Each heating element will have (2) ¼" quick disconnects for power supply wiring. In addition, the heating elements located on the inside of the module will have (2) ¼" quick disconnects for the auto reset thermal cutouts. Label and separate all of those connections. **See Figure 7.**
6. Using a 5/16" hex driver, loosen and remove the (4) self drilling screws that hold the blower plate to the frame of the unit. Remove the two screws at the top of the product last, as after they are removed, the module will be free to drop out of the cabinet. **See Figure 8** for location of all screws.
7. Wearing protective gloves, hold the module by the motor, and rotate the module top forward and drop it down through the bottom of the unit. **See Figure 9.**
8. To remove the fans and/or motor, loosen the set screws in the fan wheel hubs by using a 5/32" Allen wrench that is at least 6" long. The set screw can be accessed up through the fan's discharge.
9. Next, remove the two blower housings by removing the (8) screws that attach the fan housings to the blower plate. When the fan housings are free, slide them and their fan wheels off to each side.
10. Remove the motor clips from the motor mounts, disconnect the motor ground wire if necessary, and lift the motor up and out of its cradle.
11. Reinstall in reverse order of removal.

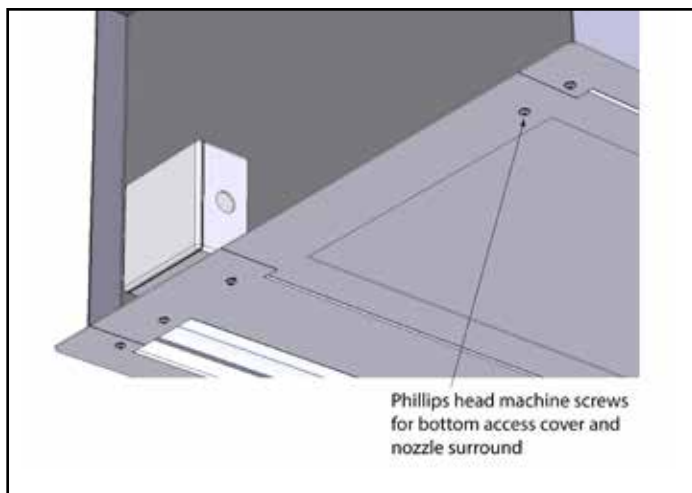

Figure 6

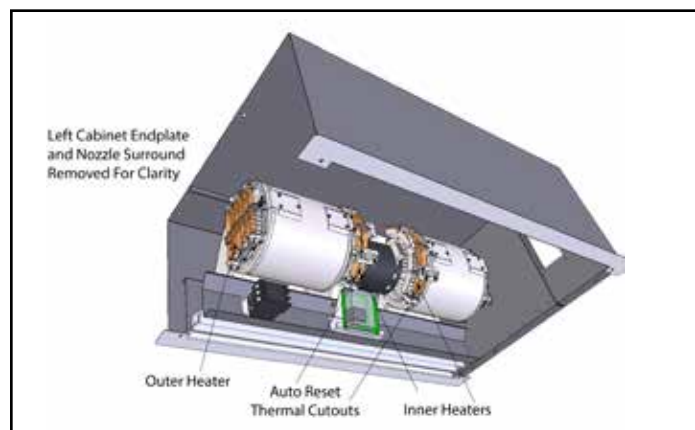

Figure 7

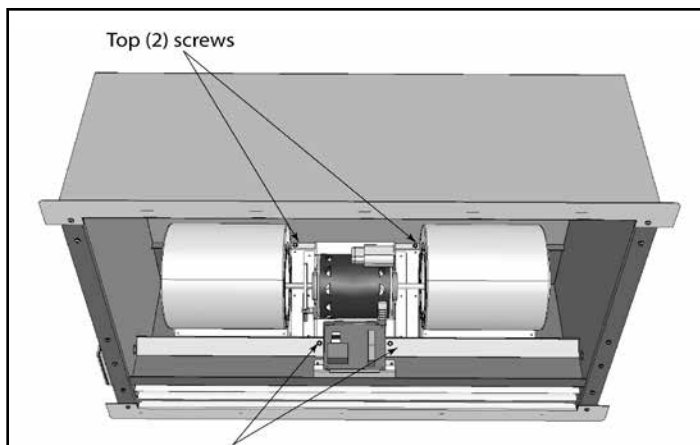

Figure 8

B. To replace the electric heater sub assembly :

1. Disconnect and lockout power to the unit.
2. Remove the bottom access cover.
3. The blower module does NOT need to be removed from the unit to replace an electric heater.
4. Label and detach the connections for supply power and for the auto reset thermal cutouts located on both inner heaters. **See Figure 7.**
5. To remove the outer heaters, remove the (3) self drilling screws from the mounting plate that is attached to the fan. **See Figure 10.**
6. To remove the inner heaters, remove the (2) self tapping screws from the mounting plate. **See Figure 10.**
7. Install new heaters. When installing the new outer heaters, be careful not to strip the holes in the thin gauge steel used on the fan housing.
8. Reconnect supply power and thermal cutout wiring.

See the following pages for information on the Intelliswitch™, including: Quick Start Operation Guide, FAQ's and Serial Network Connection

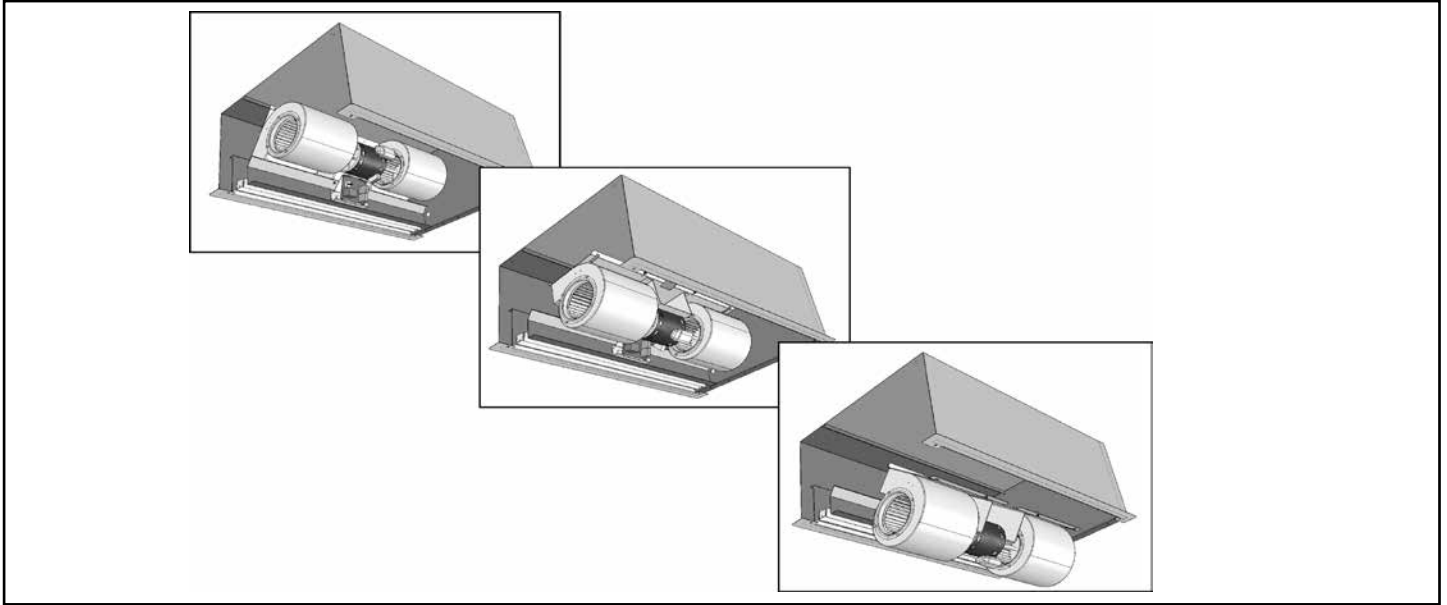

Figure 9

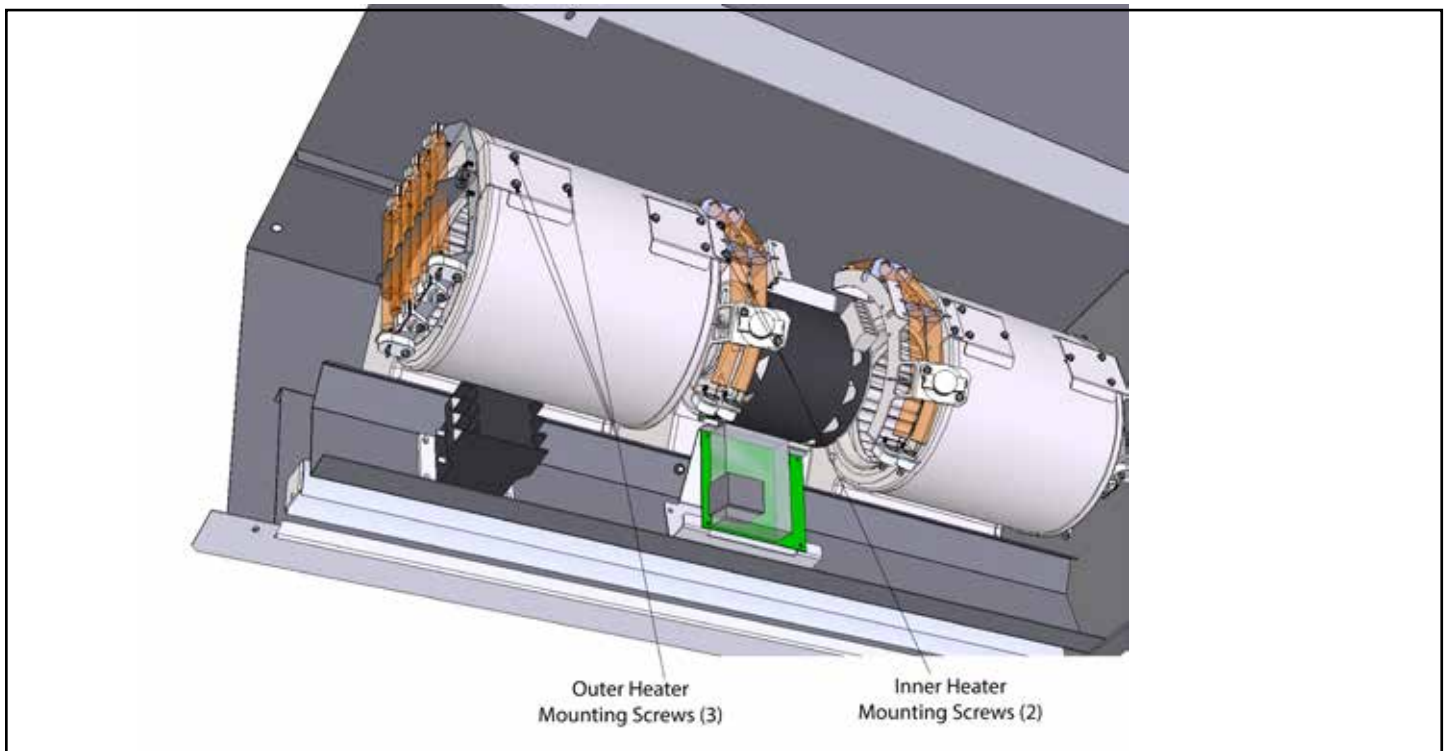

Figure 10

QUICK START INSTRUCTIONS

For your Berner Air Curtain with Intelliswitch™

www.Berner.com/intelliswitch



NOTE – to navigate use up/down to select setting and left/right to change setting

Mode/Fan Speed:

Mode: Select your mode of operation (see steps on page 2)

Fan Speed: Sets the speed of the fan

Delay Time: Amount of time the air curtain is to run after the door closes

Temp Set: Amount of heat and time the air curtain is to run after the door closes

Start Time: Programmable time of day air curtain becomes active

Stop Time: Programmable time of day air curtain stops running

T-Stat Mode: Set only heat or heat & fan

Set Time/Day: Programmable clock

Locked: Unit will run as programmed but settings cannot be changed

IMPORTANT NOTE!

If your air curtain unit is in “Locked” mode when you receive it:

Press and hold the left and right arrows simultaneously for 5 seconds to unlock.

STEP ONE



To Start: Press the Down Arrow button once.

NOTE: To change from "Mode" to "Fan Speed" press the down arrow twice.

STEP TWO



Use the Left and Right Arrows to scroll through the 8 available modes of operations

5 Standard Mode of Operation Options:

OFF

Door opens: The air curtain is off

Door shuts: The air curtain is off

ON

Door opens: The air curtain activates

Door shuts: The air curtain continues to run

AUTO

Door opens: The air curtain activates

Door shuts: The air curtain turns off

DELU

Door opens: The air curtain activates

Door shuts: The air curtain continues to run for a minimum of 60 seconds

PLUS

For heated units only

Door opens: The air curtain and heater activate and run at set speed

Door shuts: The air curtain continues to run for a minimum of 60 seconds. If thermostat is not satisfied, air curtain and heater continue to run until thermostat is satisfied. If thermostat drops below set temperature, the heater and air curtain will run until thermostat is satisfied.

3 Customizable Mode of Operation Options:

See www.berner.com/intelliswitch for programming directions

(Section 5, Program Menu).

STEP THREE



Once the **Mode of Operation** is selected, press the "OK" button

INTELLISWITCH™ Gen4 FAQ's (Frequently Asked Questions)

www.Berner.com/intelliswitch

WARNING: TO REDUCE THE RISK OF FIRE, ELECTRIC SHOCK OR INJURY TO PERSONS, OBSERVE THE FOLLOWING: Before servicing or cleaning unit, switch power off at service panel and lock the service disconnecting means to prevent power from being switched on accidentally. When the service disconnecting means cannot be locked, securely fasten a prominent warning device, such as a tag, to the service panel.

Even though every Architectural Icon is individually tested at the factory before shipment, on occasion improper functionality may be experienced. Here is a list of common questions

Q. Why can't I change my settings?

A. The Intelliswitch™ may be locked. If the Lock light is illuminated, the control is locked. To unlock, press and hold the "+" button for 5 seconds. The Lock mode can also be protected with a PASScode. If the PASScode option is on, an attempt to unlock the control will display PASS and then a 0000 prompt. The four digit code "2376" must then be entered to unlock the control. Use the "+" and "-" to select a number and the up and down arrows to select the digit to edit. Press OK when done. Note: If the AutoLock setting is on, the control will re-lock if there is no activity after 5 minutes.

Q. Why won't my heat work, even though fans are running?

- A.** The thermostat(s) may need adjusted or replaced.
1. Make sure that the thermostat probe and/or remote thermostat are in the "On" position and set above ambient (room) temperature.
 2. Check internal and external thermostat status in the Diagnostics Menu for a faulty thermostat. To do this, press the "i" button and "diag" will appear, then arrow down to the "ts" setting, if it displays "1" then the thermostat(s) is working (there is a call for heat).
 3. If no external thermostat is used, check to see if the internal thermostat probe is connected. Disconnect power to the unit, remove the bottom cover and check that the beige sheathed cable is attached to the pins on the control board marked "temp sensor". Check to see that the removable probe tip is connected to the other end of this cable. If the internal thermostat is connected and the thermostat settings are correct and you are still not getting heat, check to see if the fan speed range is correct.
 4. Check the fan speed range in the Factory Menu. First find the unit's two digit speed range on the wiring diagram shipped in the wiring compartment and attached to the inside of the bottom cover. Navigate to the factory menu to check the range. Press the info "i" button to display "diag". From here press and hold the "+" button for 5 seconds and "Fact" will display. Use the down arrow to navigate to the "rn" setting and compare the two digit number displayed. If it matches, press the "√" to exit. If it does not match, use the "+" or "-" to change the number to match exactly. Press "√" to exit.
- WARNING: setting the wrong speed range can severely damage the unit and lead to personal injury or a safety hazard.**
5. If there is still no heat, you may need a new heater relay, control board or thermal cutout: consult factory.

Q. Why won't the Intelliswitch™ light up?

- A.** There may not be power to the control.
1. Check to see if the main power is turned on to the unit. Your air curtain may have multiple disconnects, be sure all are turned on.
 2. **NOTE: ONLY QUALIFIED PERSONS SHALL CHECK POWER IN THE UNIT WITH THE POWER ON.** Verify that there is power to the control board. The power terminals are on the control board which is located inside the unit. Remove the bottom cover the access the internals and expose the power terminals. Check the line voltage at spade terminals L2 and 120, 208 or 240 (depending on the voltage supplied to the unit).
 3. Check the ribbon cable connections to the display board for a loose connector or improperly connected cable (see Installation Instructions for correct cable connection).
 4. If display still doesn't light, unplug the door switch/ remote thermostat harness and thermostat probe (if a heated unit) from the control board. If the display lights, plug one component back in at a time to see which one may be shorted. The faulty component will make the display go blank again.
 5. If there is line voltage power at the board terminals, the ribbon cable is correctly connected and the thermostat are working, and it is still not working, you may need a new control board: consult factory.

Q. Why won't my fans shut off?

- A.** The Intelliswitch™ may be in the wrong mode or mis-wired.
1. Check to see if the control is in the "ON" mode, if it is, then change the Mode to another setting.
 2. If there is a door switch and the unit is in a mode that is activated by it, there could be a short, mis-wiring or mix-up in components. Close the door and check the door switch status in the Diagnostics menu. Press the info "i" button and "diag" appears, then arrow down to the "ds" setting, if it displays "1" then the door switch signal is closed (there is a call for fan). If the door is closed, the signal should be "0" or open.
 3. There could be a short in the field connections to the door switch or the door switch leads could be mis-wired. To test, disconnect the door switch connection at the unit. Open the wiring compartment on top of the unit and be cautious of high voltage connections. Disconnect the blue wires labeled 9 & 10 from the field wiring to the door switch or make sure they are not tied together. There is no danger of getting shocked because the signal is 5 volt DC. Be sure not to touch the blue wires to anything metal (or grounded). The unit should shut off when it is in any mode that is activated by the door switch.

Continued on next page ...

INTELLISWITCH™ FAQ's Continued (Frequently Asked Questions)

www.Berner.com/intelliswitch

4. If the air curtain is heated, make sure that the thermostat isn't wired to the door switch leads. Door switch leads are blue and labeled 9 & 10.

Q. How can I check the door switch to be sure it's working?

A. The Intelliswitch™ may be in the wrong mode, be mis-wired or have a faulty door switch.

1. First test the wiring and controller function at the same time. Locate the door switch and open its wiring compartment. There should be two wires connected to screws inside the switch. There is no danger of getting shocked because the signal is 5 volt DC. Be sure not to touch the wires to anything metal (or grounded). With air curtain in "Auto" mode, either disconnect both wires from the screws (marking which screws the wires are under) and touch them together or make a short jumper wire and touch the jumper to both screws at the same time to see if air curtain comes on. If it does, the controller and wiring work.
2. If the wiring and unit pass the function test, the problem could be either misalignment or a faulty door switch. On a magnetic reed switch check for magnet alignment, for plunger/roller type switch, check contact engagement with door.
3. If you have access to an electrical test meter, the door switch contacts can be tested for continuity when the door switch wires are disconnected from the unit.

Q. Why won't my heat shut off?

A. The Intelliswitch may need adjusted, have been mis-wired or have a faulty thermostat.

1. Heat is activated by one of two thermostat connections. To test the internal thermostat set the external thermostat to OFF. The settings of the unit mounted thermostat probe are accessed through the display. Press the down arrow until the Temp Set indicator lights up; check if the temperature setting and unit of measure are correct. Test to see if it shuts off by setting the thermostat temperature to OFF or lower than the room temperature.
2. If an external thermostat is connected to the unit, there could be a short in the field connections or the thermostat leads may be mis-wired. To test the external thermostat set the internal thermostat to OFF. Disconnect the external thermostat connections at the unit. Open the wiring compartment on top of the unit and be cautious of high voltage connections. Disconnect the orange wires labeled 6 & 7 from the field wiring or make sure they are not tied together. There is no danger of getting shocked because the signal is 5 volt DC. Be sure not to touch the orange wires to anything metal (or grounded). The heat should shut off when the wires are separated. For more complex troubleshooting of either thermal cutouts or heater relays, please consult a qualified electrician or consult the factory.

Q. Why didn't the Intelliswitch™ save the changes I made to a program?

A. If a program is active (a dot is illuminated under one of the clock digits), changes can be made to any settings on the User Menu. These changes however will only remain in effect until the program changes to the next time zone. To make changes permanent, settings must be changed in the program from the Program Menu. Access the Program Menu by holding down the "-" button for 5 seconds until "Pro" is displayed. Arrow down to select the program to edit and press "√" to select the program editor. Use the down arrow to step through the options and make changes as desired using the "+" and "-". Continue to press the down arrow until "Stor" is displayed. Press "√" to keep or store the changes.

Q. How do I undo a change that I made to a program in the Program Menu?

A. Changes to programs cannot be undone.

1. Changes can be changed back by going to the programming menu and re-editing the program back to what it was or resetting all programs back to factory default.
2. Resetting the programs to the factory default must be done on the Factory Menu. Access to the Factory Menu is from the Diagnostics Menu. Press the info "i" button and "diag" is displayed. From the "diag" display press and hold the "+" for 5 seconds until "Fact" is displayed. Use the down arrow to select "DEFn" on the display then use the "+" to select "DEFP". Press "√" to reset. The control display will go blank then blink as confirmation.

Q. My air curtain won't turn on?

A. The Start and Stop time must be set to the exact same time for the unit to be active full time. Check the AM/PM setting on the Start and Stop times or the clock (considering the PM indicator light when setting values). If a program is being used, check to see if a program is active that may have different start/stop times than those expected.

Q. My building has a Building Management System, can the Intelliswitch work with a BMS?

A. The Intelliswitch can be controlled by a Building Management System (BMS) but currently does not have the ability to communicate directly with them. Dry contacts on the BMS may be used to control the unit activation through the door switch connections (blue wires 9 & 10) and the heat activation through the remote thermostat connections (orange wires 6 & 7). Consult factory.

IX. TROUBLESHOOTING

SYMPTOMS	CAUSE	REMEDY	
NO AIR	<ul style="list-style-type: none"> Power supply line open (no power) Fuse blown/circuit breaker tripped Motor overload tripped Failed switch 	<ul style="list-style-type: none"> Check power source, check service disconnect, check method of control in ON position Replace fuse(s)/reset breaker Internally protected motor - should reset automatically after cool-down, if not, replace motor. Replace switch 	
	MOTOR RUNNING/FANS ARE NOT ROTATING		
	<ul style="list-style-type: none"> Broken or damaged flexible hub Shaft rotating inside fan 	<ul style="list-style-type: none"> Replace fan sleeve/reengage coupling Tighten set screws/tighten fan on shaft 	
ELECTRICAL CONTROLS NOT FUNCTIONING WHEN DOOR IS OPEN			
MINIMUM AIR	<ul style="list-style-type: none"> Air directional discharge vanes mis-adjusted Inadequate intake clearance Blower motor operates below speed Fan rubbing against housing Fan wheels clogged with dirt Fan in backwards 	<ul style="list-style-type: none"> Adjust vanes to proper position, see instructions Move air curtain or remove obstruction Provide adequate space for air curtain Improper voltage Free fan from housing Clean and vacuum fan wheels Check fans for blade curve toward discharge 	
	<ul style="list-style-type: none"> Air stream too weak Air stream hits obstruction Negative pressure 	<ul style="list-style-type: none"> Selector switch is in off position Door limit switch not operating 	<ul style="list-style-type: none"> Turn switch to "ON" position Repair or replace limit switch
		<ul style="list-style-type: none"> Adjust nozzle to proper position, adjust motor speed; see installation instructions Remove obstruction or reposition air curtain (move out 3/8" for every 1" up from the door) Relieve negative pressure by providing makeup air 	
UNEVEN AIR	<ul style="list-style-type: none"> Shaft rotating inside fan One motor not operating 	<ul style="list-style-type: none"> Tighten set screws Repair or replace motor 	
EXCESSIVE AIR MOVEMENT AT DOORWAY	<ul style="list-style-type: none"> Nozzle not angled out far enough Unit too powerful Air movement too cold Pushing air outside building <p>SEE AIR IS NOT HITTING FLOOR SYMPTOMS</p>	<ul style="list-style-type: none"> Adjust nozzle angle to outside Adjust motor speed Add auxiliary heat to overcome wind chill factor Adjust discharge angle back into building, adjust motor speed 	

ELECTRICALLY HEATED MODELS

NO HEAT	<ul style="list-style-type: none"> Switch turned to "ON" position Thermostat not set properly Coils burned out due to lack of air Automatic reset thermal cutout failed in open position Manual reset thermal cutout tripped (if supplied) 	<ul style="list-style-type: none"> Replace switch or check wiring Change thermostat setting Correct airflow problem; replace coils Replace automatic thermal cutout Reset manual thermal cutout
MINIMAL HEAT	<ul style="list-style-type: none"> Thermostat in wrong location - thermostat too close to discharge Improper voltage Thermostat not set properly Low entering air temperature 	<ul style="list-style-type: none"> Move thermostat away from air stream Supply proper voltage Change temperature setting Based on unit temperature rise, reduce speed
EXCESSIVE HEAT	<ul style="list-style-type: none"> Incorrect speed range Thermostat in wrong location Thermostat not set properly Insufficient air over coil Improper voltage 	<ul style="list-style-type: none"> Check Factory Menu speed range matches diagram Move the thermostat closer to air stream Change temperature setting Remove restriction on intake Supply proper voltage

HOT WATER HEATED UNITS

EXCESSIVE HEAT	<ul style="list-style-type: none"> Too high hot water pressure Inadequate air flow, fins plugged up, dirty coils 	<ul style="list-style-type: none"> Reduce hot water flow Clean intake and coils
MINIMAL HEAT	<ul style="list-style-type: none"> Water temperature too low Intake air below design temperature 	<ul style="list-style-type: none"> Increase water flow Increase water flow

X. APPENDIX

A. Serial Network Connection

NOTE: ONLY AIR CURTAINS FROM THE SAME SERIES CAN BE NETWORKED TOGETHER. IF UNITS FROM DIFFERENT SERIES ARE NETWORKED OR ARE INCOMPATIBLE, AN ER61 WILL DISPLAY EVERY TIME A COMMAND IS ENTERED.

Serial Network Connection Operation

For Serial Network Connection a serial cable connection must be made between all Intelliswitch™ controls of each air curtain to be linked. Once air curtains are linked all Menu settings made through any air curtain display or remote control will transfer to all other linked air curtain. Parameter changes made on any linked air curtain will update all other boards “live” upon menu selections.

1. All air curtains equipped with an Intelliswitch and the Serial Communication Option have two RJ11 connectors (telephone plug) located in the wiring compartment. Serial cable(s) with the corresponding RJ11 socket (telephone jack) on each end are shipped separately.
2. Once the air curtains are installed, connect all units that are to be networked together using the serial cable(s) and either of the two RJ11 connectors in each wiring compartment. For example, two units networked together require one cable and leaves an unused connector in each wiring compartment. Three units networked together requires two serial cables, leaves two units with one connector unused in each wiring compartment and one unit with both connectors used.
3. A wiring diagram is included in the wiring compartment of each air curtain and illustrates the provision where the serial cable is connected to network additional air curtains.
4. Once all serial cables are connected and all air curtains have power the units can be programmed from any handheld remote or air curtain display on the network. All program settings are included in the installation instructions shipped with the air curtain.
5. If the air curtains were purchased with the WiFi option, when connected to the local WiFi network they can be programmed from a smart phone using the Berner app.

Serial Network Connection - Settings

When units with the Intelliswitch™ are operated in a network there are three options available under the Programming Menu that manage how they interact with each other.

- Door Switch (door)
- Thermostat (temp)
- Stand By (Stby)

Each option can be set to “ind” or “ALL”.

“ind” = the option only is activated on this unit or independent of the other units

“ALL” = the option activates ALL of the units connected on the network

1. To access the Serial Network Connection hold the left arrow for 5 seconds and “Pro” will display
2. Use the left/right arrows to locate the desired option (door/temp/Stby)

3. When located, use the down arrow to enter into that setting.
4. Use the left/right arrow to change the setting between “ind” and “ALL”

EXAMPLE: Stand By function

If set to independent, when STOP is pressed only the unit where STOP is pressed will stop. If set to ALL, all of the connected units set to ALL will stop.

EXAMPLE: Door Switch function

If set to independent, the door switch connected to a unit will only activate that unit. If set to ALL, all of the connected units set to ALL will activate.

B. Remote Mounted Display Faceplate -

for operation of the Intelliswitch™ through a remote mounted display faceplate.

NOTE: Maximum mounting distance between the Display Faceplate and the unit is 20’. The unit MUST be factory ordered with the remote mounted faceplate option. When the remote faceplate option is ordered from the factory the air curtain comes equipped with the blank faceplate and 20’ ribbon attached. The Display Faceplate is shipped loose ready for field installation.

1. Locate the male end of the 14-conductor ribbon cable in the wiring tray and run to the remote display location. The cable is minimum CL2 rated and should not need to be in conduit.
2. Connect the ribbon cable to the 14-pin socket with red stripe positioned on the top left when facing the front of the display board.
3. Mount remote faceplate to the wall.
4. Reinstall the wiring tray cover.

C. Infra-red Remote Control

The handheld infra-red remote control buttons, layout and operation are the same as that on the Intelliswitch™ air curtain display (including multiple button presses) with one exception, the Lock Button.

There is no need for multi-button press and hold for lock/unlock activation. The Lock Button will lock/unlock display in one press.

The Infra-red Remote Control has a range of 15 feet.

D. BACnet-IP Integration

If the unit was ordered with the Berner AIR (smart controller & app), then it is BACnet compatible.

1. To connect wirelessly to the Building Management System using BACnet-IP: download the Berner AIR App, pair the air curtain to the app, and then in the settings menu select the BACnet option. Follow the prompts to configure the BACnet controller.
2. To connect via wire: this air curtain includes an ethernet connection in the wiring compartment to connect to the Building Management System via BACnet-IP. Connect a CAT 5 ethernet cable (provided by others). Once wired, download the Berner AIR App, pair the air curtain to the app and then in the settings menu select the BACnet option. Follow the prompts to configure the BACnet controller.

XI. WARRANTY

Berner International ("The Company") warrants all new equipment to be free of defects in workmanship and material for a period of five years (5 years) on unheated models and two years (2 years) on heated models from the original date of shipment, provided the equipment has been properly cared for, installed and operated in accordance with the limits specified on the nameplate and The Company's instructions. All warranted parts will be replaced at no charge for a period of six months from date the parts were shipped.

The Company will correct by repair or replacement, at its option and expense, any proven defects in said apparatus, subject to the above conditions, provided that immediate written notice of such defects is given to The Company. The warranty does not include any labor incurred for the removal or installation of defective part(s). The Company reserves the right to inspect, or have inspected by a qualified representative, any apparatus at the place of installation before authorizing repair or replacement. Repair or replacement will be made F.O.B. factory with any applicable transportation charges to be borne by the customer. Merchandise not of The Company's manufacture supplied in piece, or in component assemblies, is not covered by the above warranty, but The Company will give the customer the benefit of any adjustment as made with the Manufacturer.

This warranty is void if the apparatus has been tampered with in any way or shows evidence of misuse.

The Company will not assume any expense or liability for repairs made outside its factory without proper written consent from its service manager, nor for any transportation charges on apparatus returned to the factory without written authorization by The Company.

Nothing in the above warranty provisions, however, shall impose any liability or obligation of any type, nature or description upon Berner International if Berner has not received payment in full for the apparatus in question.

THERE ARE NO WARRANTIES WHICH EXTEND BEYOND THE DESCRIPTION ON THE FACE HEREOF INCLUDING THE IMPLIED WARRANTY OF MERCHANTABILITY AND FITNESS FOR A PARTICULAR PURPOSE.

LIMITATION OF DAMAGES

Notwithstanding anything to the contrary above, customer's exclusive remedy for any and all losses or damages resulting from the sale of The Company's equipment under this agreement, including but not limited to, any allegations of breach of warranty, breach of contract, negligence or strict liability, shall be limited, at The Company's option, to either the return of the purchase price or the replacement of the particular equipment for which a claim is made and proved. In no event shall The Company be liable for any special, consequential, incidental or indirect losses or damages from the sale of The Company's equipment under this agreement.

SERIAL NUMBER

DATE PURCHASED



Saving energy and creating healthy, comfortable environments

BERNER INTERNATIONAL
New Castle, Pennsylvania

724-658-3551 • 1-800-245-4455 • www.Berner.com

Berner reserves the right to alter specifications without prior notice.