



INDUSTRIAL WASHDOWN DUTY 12

Ambient (Unheated) Air Curtain

Data Sheet

Recommended for Mounting Heights to 12' (environmental separation) and 10' (insect control)

STANDARD CONSTRUCTION

- ½ hp single speed washdown duty totally enclosed motor(s)
- Stainless steel cabinet with stainless steel inlet screen & access panels
- Stainless steel blower wheels & housings
- Front air intake
- High efficiency Pro-V Nozzle

5 Year
Limited
Warranty



MODEL	Nozzle Width (in)	Max Vel. at Nozzle (fpm)	Avg. Outlet Vel. (fpm)	Air Volume (cfm)	Outlet Vel. Uniformity	Power Rating (kW)	Motor(s) @ hp	Net Wt. (lbs)
WD12-C-1036A	36.00	5,166	1,728	1,512	87%	0.51	1 @ 1/2	100
WD12-C-1042A	42.00	5,550	1,551	1,583	89%	0.52	1 @ 1/2	106
WD12-C-1048A	48.00	5,292	1,366	1,594	78%	0.53	1 @ 1/2	111
WD12-C-1060A	66.00	5,079	1,019	1,634	74%	0.54	1 @ 1/2	122
WD12-C-2060A	66.00	4,781	2,010	2,931	85%	0.99	2 @ 1/2	169
WD12-C-2072A	72.00	5,166	1,728	3,024	87%	1.02	2 @ 1/2	178
WD12-C-2078A	78.00	5,166	1,633	3,095	87%	1.03	2 @ 1/2	184
WD12-C-2084A	84.00	5,550	1,551	3,166	89%	1.04	2 @ 1/2	189
WD12-C-2096A	99.00	5,292	1,366	3,188	78%	1.06	2 @ 1/2	199
WD12-C-3096A	99.00	4,781	1,846	4,443	85%	1.50	3 @ 1/2	240
WD12-C-2108A	108.00	5,079	1,230	3,228	74%	1.07	2 @ 1/2	242
WD12-C-3108A	108.00	5,166	1,728	4,536	87%	1.53	3 @ 1/2	283
WD12-C-2120A	117.00	5,079	1,149	3,268	74%	1.08	2 @ 1/2	249
WD12-C-3120A	117.00	5,166	1,604	4,678	87%	1.55	3 @ 1/2	290
WD12-C-3132A	132.00	5,292	1,484	4,760	78%	1.57	3 @ 1/2	311
WD12-C-3144A	144.00	5,292	1,366	4,782	78%	1.59	3 @ 1/2	325
WD12-C-4144A	144.00	5,166	1,728	6,048	87%	2.04	4 @ 1/2	366
WD12-C-4156A	156.00	5,166	1,633	6,190	87%	2.06	4 @ 1/2	382
WD12-C-4168A	168.00	5,550	1,551	6,332	89%	2.08	4 @ 1/2	394
WD12-C-4180A	180.00	5,292	1,452	6,354	78%	2.10	4 @ 1/2	407
WD12-C-5180A	180.00	5,166	1,728	7,560	87%	2.55	5 @ 1/2	448
WD12-C-4192A	192.00	5,292	1,366	6,376	78%	2.12	4 @ 1/2	419
WD12-C-5192A	192.00	5,292	1,635	7,631	78%	2.56	5 @ 1/2	460

NOTES:

1. Operation at 50 Hz will generate approximately a 17% reduction in air performance.
 2. Consult factory for vertically mounted units
- Berner does not recommend WD12-C-1060A, WD12-C-2108A and WD12-C-2120A, exist only as an equivalent to competitors' models.
See sheet EP-400-WD for amp draws/total load requirements.

MODEL NUMBER CONFIGURATION

WD12-C-1 036 A A-F-SS

Series	# of Motors	Opening Width	Heat	Voltage	Intake	Cabinet Finish
WD12-C	1, 2, 3, 4, 5	036" - 192"	A=Ambient	A=120/1/60 B=208/1/60 J=240/1/60 D=208/3/60 E=240/3/60 H=480/3/60 I=600/3/60	T=Top	SS=Stainless Steel

VELOCITY PROFILE: Model WD12-C-1036A			
Distance from Nozzle (ft)	3	6.5	10
Core Velocity (fpm)	2633	1867	1578

Berner reserves the right to alter specifications without prior notice.

www.berner.com Berner International 800.245.4455
111 Progress Ave. / New Castle / PA / 16101 / USA

DS-400-WD
November, 2023



INDUSTRIAL WASHDOWN-DUTY 12

Ambient (Unheated) Air Curtain
Electrical Performance Sheet

MODEL	120/1/60 (voltage code A) MOTOR AMP DRAW = 7.4 each			208/1/60 (voltage code B) MOTOR AMP DRAW = 4.3 each			240/1/60 (voltage code J) MOTOR AMP DRAW = 3.7 each			208/3/60 (voltage code D) MOTOR AMP DRAW = 2.5 each		
	# CKTS	AMPS PER CIRCUIT	BREAKER RATING PER CIRCUIT	# CKTS	AMPS PER CIRCUIT	BREAKER RATING PER CIRCUIT	# CKTS	AMPS PER CIRCUIT	BREAKER RATING PER CIRCUIT	# CKTS	AMPS PER CIRCUIT	BREAKER RATING PER CIRCUIT
WD12-C-1036A WD12-C-1042A WD12-C-1048A WD12-C-1060A	1	7.4	15	1	4.3	15	1	3.7	15	1	2.5	15
WD12-C-2060A WD12-C-2072A WD12-C-2078A WD12-C-2084A WD12-C-2096A WD12-C-2108A WD12-C-2120A	1	14.8	20	1	8.6	15	1	7.4	15	1	5.0	15
WD12-C-3096A WD12-C-3108A WD12-C-3120A WD12-C-3132A WD12-C-3144A	1	22.2	30	1	12.9	20	1	11.1	15	1	7.5	15
WD12-C-4144A WD12-C-4156A WD12-C-4168A WD12-C-4180A WD12-C-4192A	1	29.6	40	1	17.2	25	1	14.8	20	1	10.0	15
WD12-C-5180A WD12-C-5192A	1	37.0	50	1	21.5	30	1	18.5	25	1	12.5	20

Berner reserves the right to alter specifications without prior notice.



INDUSTRIAL WASHDOWN-DUTY 12

Ambient (Unheated) Air Curtain
Electrical Performance Sheet

MODEL	240/3/60 (voltage code E) MOTOR AMP DRAW = 2.4 each			480/3/60 (voltage code H) MOTOR AMP DRAW = 1.2 each			600/3/60 (voltage code I) MOTOR AMP DRAW = 0.8 each		
	# CKTS	AMPS PER CIRCUIT	BREAKER RATING PER CIRCUIT	# CKTS	AMPS PER CIRCUIT	BREAKER RATING PER CIRCUIT	# CKTS	AMPS PER CIRCUIT	BREAKER RATING PER CIRCUIT
WD12-C-1036A WD12-C-1042A WD12-C-1048A WD12-C-1060A	1	2.4	15	1	1.2	15	1	0.8	15
WD12-C-2060A WD12-C-2072A WD12-C-2078A WD12-C-2084A WD12-C-2096A WD12-C-2108A WD12-C-2120A	1	4.8	15	1	2.4	15	1	1.6	15
WD12-C-3096A WD12-C-3108A WD12-C-3120A WD12-C-3132A WD12-C-3144A	1	7.2	15	1	3.6	15	1	2.4	15
WD12-C-4144A WD12-C-4156A WD12-C-4168A WD12-C-4180A WD12-C-4192A	1	9.6	15	1	4.8	15	1	3.2	15
WD12-C-5180A WD12-C-5192A	1	12.0	15	1	6.0	15	1	4.0	15

Berner reserves the right to alter specifications without prior notice.

WD12-C AMBIENT SYSTEM

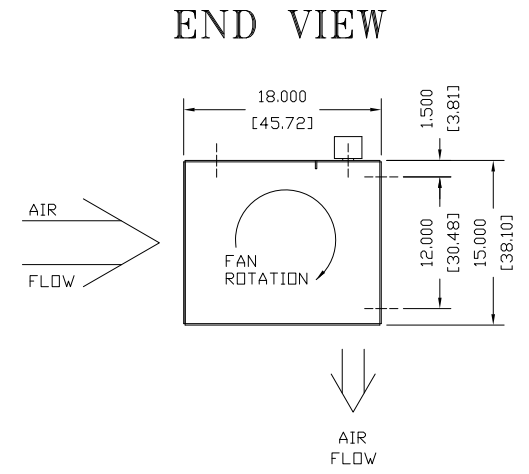
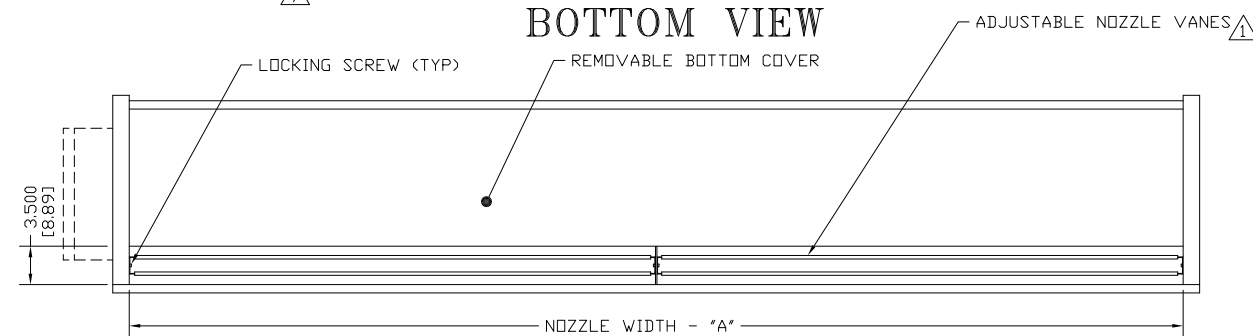
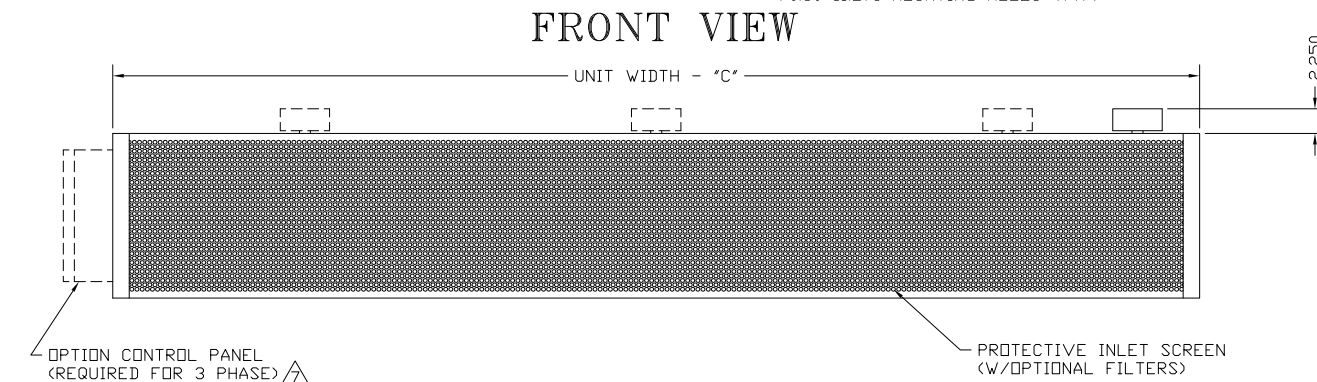
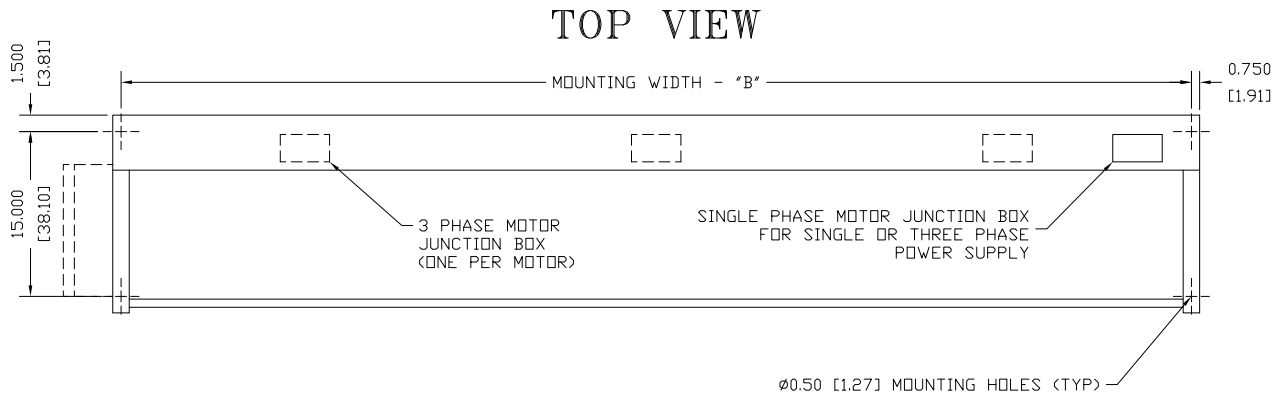

NOTES:

- ⚠ AIR CURTAIN MUST BE INSTALLED SO AIR STREAM IS NOT OBSTRUCTED WHEN DEFLECTED 20° TO EITHER SIDE OF \bar{C} .
- ⚠ ELECTRICAL CONNECTIONS TO BE FLEXIBLE.
- ⚠ FIELD VERIFY DIMENSIONS.
- ⚠ ANCHORS TO SUPPORTING STRUCTURE BY OTHERS.
- ⚠ ADEQUACY OF SUPPORTING STRUCTURE IS TO BE VERIFIED BY A PROFESSIONAL STRUCTURAL ENGINEER.
- ⚠ LETTER "A" IN MODEL NUMBER DESIGNATES, AMBIENT UNIT.
- ⚠ STANDARD CONTROL PANEL LEFT HAND MOUNT, OPTIONAL RIGHT HAND MOUNT, OR REMOTE. PLEASE SPECIFY.
- ⚠ DIMENSIONS IN INCHES [CENTIMETERS].

MODEL ⚠	NOZZLE WIDTH "A"	MOUNTING WIDTH "B"	UNIT WIDTH "C"
WD12-C-1036A	36.00 [91.44]	37.50 [95.25]	39.00 [99.06]
WD12-C-1042A	42.00 [106.68]	43.50 [110.49]	45.00 [114.30]
WD12-C-1048A	48.00 [121.92]	49.50 [125.73]	51.00 [129.54]
WD12-C-1060A/2060A	66.00 [167.64]	67.50 [171.45]	69.00 [175.26]
WD12-C-2072A	72.00 [182.88]	73.50 [186.69]	75.00 [190.50]
WD12-C-2078A	78.00 [192.12]	79.50 [201.93]	81.00 [205.74]
WD12-C-2084A	84.00 [213.36]	85.50 [217.17]	87.00 [220.98]
WD12-C-2096A/3096A	99.00 [251.46]	100.50 [255.27]	102.00 [259.08]
WD12-C-2108A/3108A	108.00 [274.32]	109.50 [278.13]	111.00 [281.94]
WD12-C-2120A/3120A	117.00 [297.18]	118.50 [300.99]	120.00 [304.80]
WD12-C-3132A	132.00 [335.28]	133.50 [339.09]	135.00 [342.90]
WD12-C-3144A/4144A	144.00 [365.76]	145.50 [369.57]	147.00 [373.38]

PROJECT		TITLE:	BERNER
LOCATION			MODEL WD12-C AIR CURTAIN
ARCHITECT			WASHDOWN DUTY AMBIENT SYSTEM
ENGINEER			
DWG. NO.	WD12-C-AMBI		
DATE	21JAN2021		
BY	S. Beil		
REPLACES	-		
BY	-		
BERNER INTERNATIONAL CORP. NEW CASTLE, PA.			

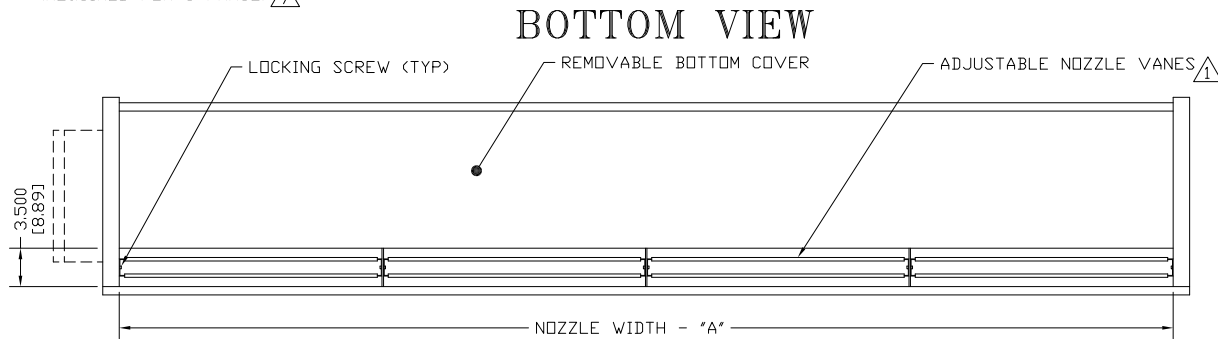
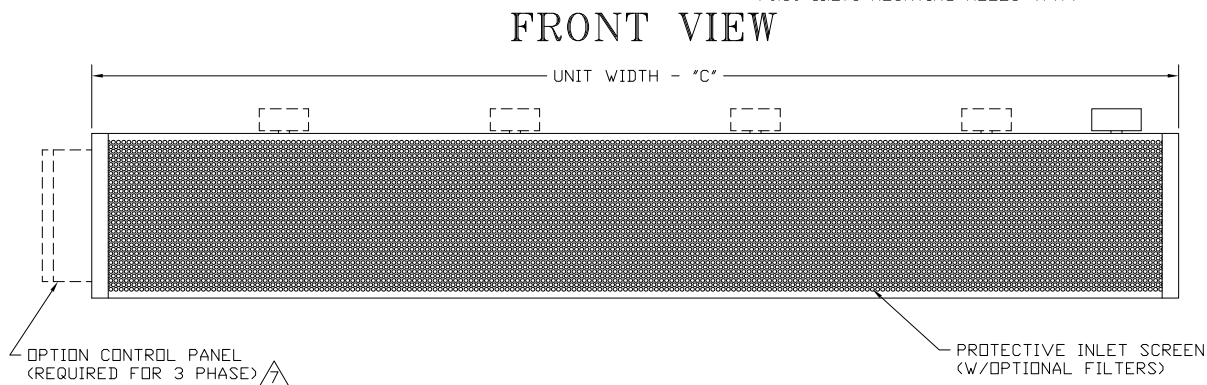
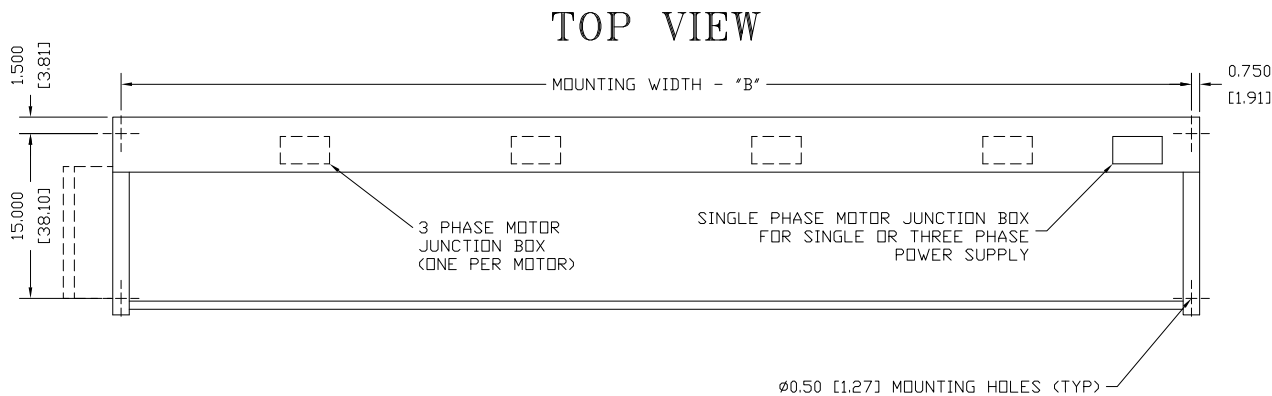

MODEL ⚠	NOZZLE WIDTH "A"	MOUNTING WIDTH "B"	UNIT WIDTH "C"
WD12-C-4156A	156.00 [396.24]	157.50 [400.05]	159.00 [403.86]
WD12-C-4168A	168.00 [426.72]	169.50 [430.53]	171.00 [434.34]
WD12-C-4180A/5180A	180.00 [457.20]	181.50 [461.01]	183.00 [464.82]
WD12-C-4192A/5192A	192.00 [487.68]	193.50 [491.49]	195.00 [495.30]

WD12-C AMBIENT SYSTEM

END VIEW

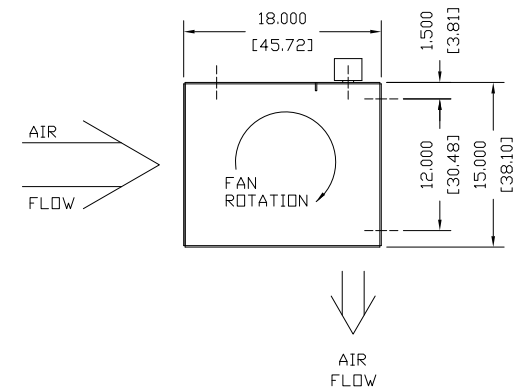

NOTES:

- ⚠ AIR CURTAIN MUST BE INSTALLED SO AIR STREAM IS NOT OBSTRUCTED WHEN DEFLECTED 20° TO EITHER SIDE OF C.
- ⚠ ELECTRICAL CONNECTIONS TO BE FLEXIBLE.
- ⚠ FIELD VERIFY DIMENSIONS.
- ⚠ ANCHORS TO SUPPORTING STRUCTURE BY OTHERS.
- ⚠ ADEQUACY OF SUPPORTING STRUCTURE IS TO BE VERIFIED BY A PROFESSIONAL STRUCTURAL ENGINEER.
- ⚠ LETTER "A" IN MODEL NUMBER DESIGNATES, AMBIENT UNIT.
- ⚠ STANDARD CONTROL PANEL LEFT HAND MOUNT, OPTIONAL RIGHT HAND MOUNT, OR REMOTE. PLEASE SPECIFY.
- ⚠ DIMENSIONS IN INCHES [CENTIMETERS].

PROJECT		
LOCATION		
ARCHITECT		
ENGINEER		
DWG. NO.	WD12-C-AMB2	TITLE: BERNER
DATE	21JAN2021	MODEL WD12-C AIR CURTAIN
BY	S. Beil	WASHDOWN DUTY AMBIENT SYSTEM
REPLACES	-	
BY	-	BERNER INTERNATIONAL CORP. NEW CASTLE, PA.

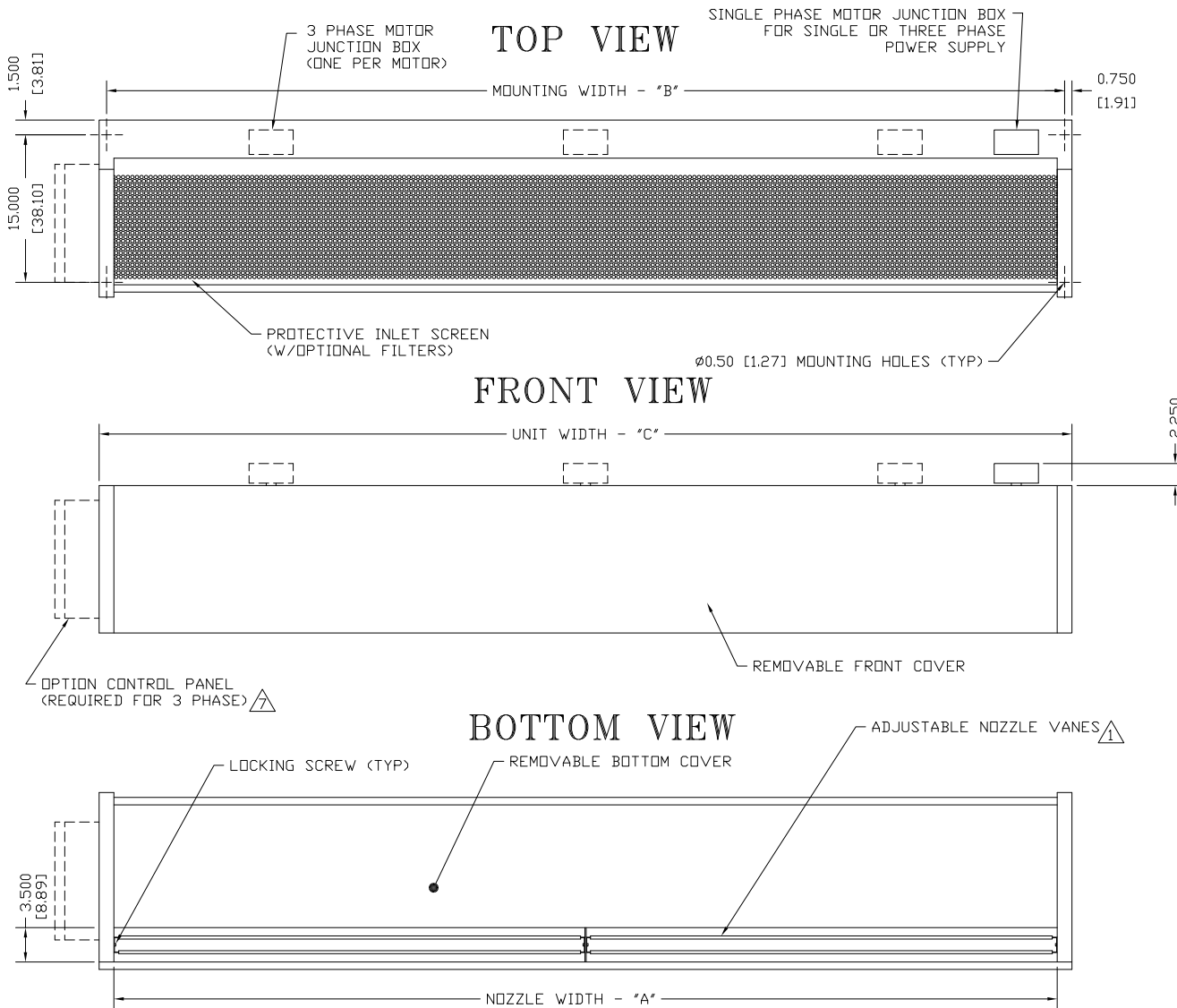

WD12-C AMBIENT SYSTEM TOP INTAKE

END VIEW

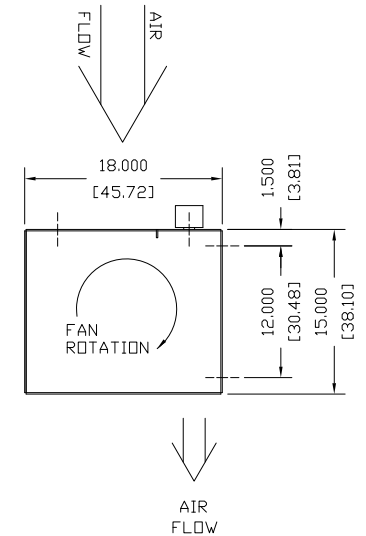

NOTES:

- ① AIR CURTAIN MUST BE INSTALLED SO AIR STREAM IS NOT OBSTRUCTED WHEN DEFLECTED 20° TO EITHER SIDE OF \bar{C} .
- ② ELECTRICAL CONNECTIONS TO BE FLEXIBLE.
- ③ FIELD VERIFY DIMENSIONS.
- ④ ANCHORS TO SUPPORTING STRUCTURE BY OTHERS.
- ⑤ ADEQUACY OF SUPPORTING STRUCTURE IS TO BE VERIFIED BY A PROFESSIONAL STRUCTURAL ENGINEER.
- ⑥ LETTER "A" IN MODEL NUMBER DESIGNATES, AMBIENT UNIT.
- ⑦ STANDARD CONTROL PANEL LEFT HAND MOUNT, OPTIONAL RIGHT HAND MOUNT, OR REMOTE. PLEASE SPECIFY.
- ⑧ DIMENSIONS IN INCHES [CENTIMETERS].

MODEL ⑧	NOZZLE WIDTH "A"	MOUNTING WIDTH "B"	UNIT WIDTH "C"
WD12-C-1036A	36.00 [91.44]	37.50 [95.25]	39.00 [99.06]
WD12-C-1042A	42.00 [106.68]	43.50 [110.49]	45.00 [114.30]
WD12-C-1048A	48.00 [121.92]	49.50 [125.73]	51.00 [129.54]
WD12-C-1060A/2060A	66.00 [167.64]	67.50 [171.45]	69.00 [175.26]
WD12-C-2072A	72.00 [182.88]	73.50 [186.69]	75.00 [190.50]
WD12-C-2078A	78.00 [192.12]	79.50 [201.93]	81.00 [205.74]
WD12-C-2084A	84.00 [213.36]	85.50 [217.17]	87.00 [220.98]
WD12-C-2096A/3096A	99.00 [251.46]	100.50 [255.27]	102.00 [259.08]
WD12-C-2108A/3108A	108.00 [274.32]	109.50 [278.13]	111.00 [281.94]
WD12-C-2120A/3120A	117.00 [297.18]	118.50 [300.99]	120.00 [304.80]
WD12-C-3132A	132.00 [335.28]	133.50 [339.09]	135.00 [342.90]
WD12-C-3144A/4144A	144.00 [365.76]	145.50 [369.57]	147.00 [373.38]

PROJECT		
LOCATION		
ARCHITECT		
ENGINEER		
DWG. NO.	WD12-C-AMB3	TITLE: BERNER
DATE	21JAN2021	MODEL WD12-C AIR CURTAIN
BY	S. Beil	WASHDOWN DUTY AMBIENT SYSTEM TOP INTAKE
REPLACES	-	
BY	-	BERNER INTERNATIONAL CORP. NEW CASTLE, PA.

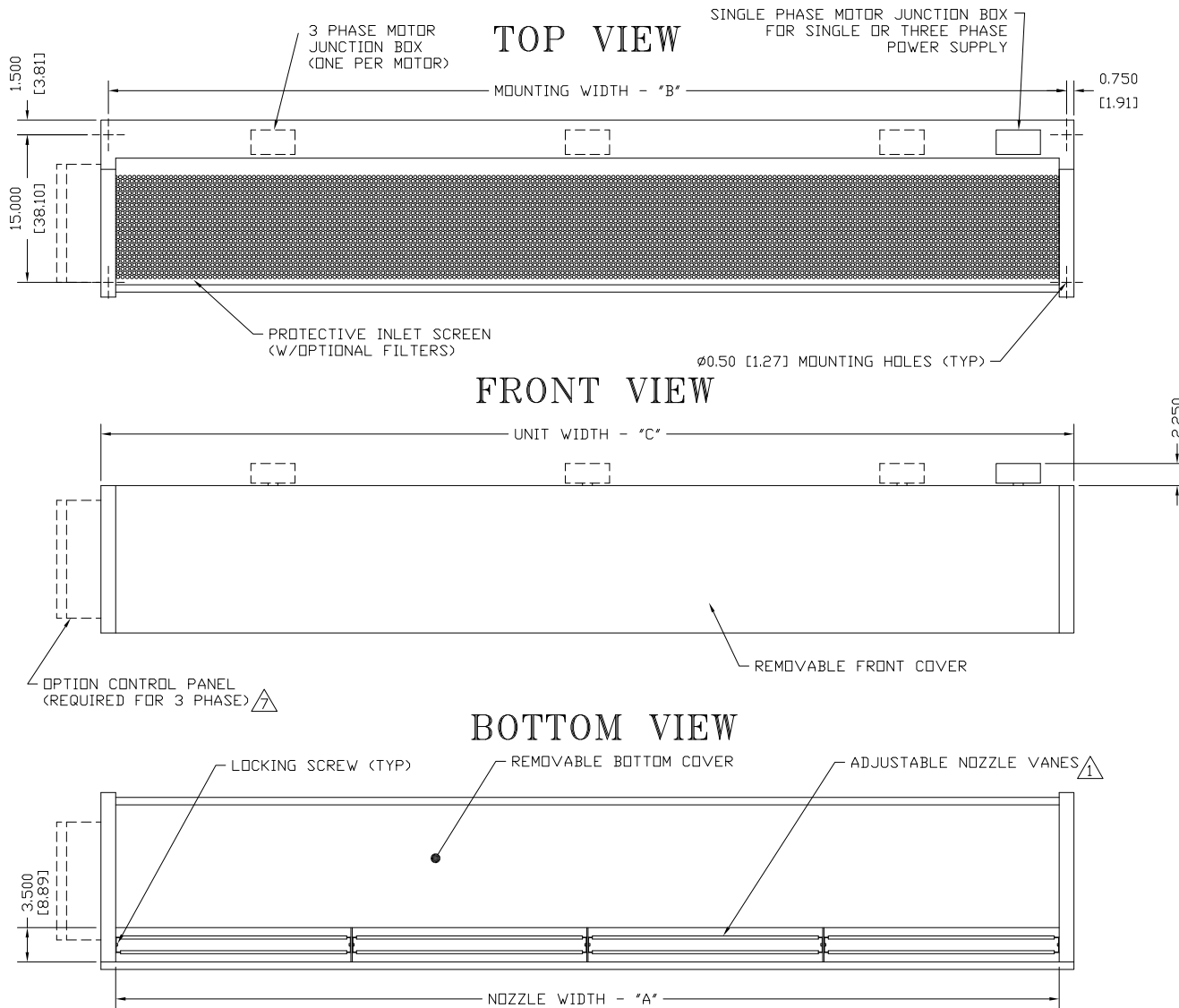

WD12-C AMBIENT SYSTEM TOP INTAKE

END VIEW

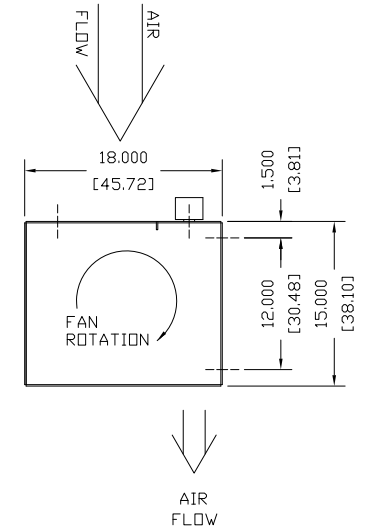

NOTES:

- ⚠ AIR CURTAIN MUST BE INSTALLED SO AIR STREAM IS NOT OBSTRUCTED WHEN DEFLECTED 20° TO EITHER SIDE OF ϕ .
- ⚠ ELECTRICAL CONNECTIONS TO BE FLEXIBLE.
- ⚠ FIELD VERIFY DIMENSIONS.
- ⚠ ANCHORS TO SUPPORTING STRUCTURE BY OTHERS.
- ⚠ ADEQUACY OF SUPPORTING STRUCTURE IS TO BE VERIFIED BY A PROFESSIONAL STRUCTURAL ENGINEER.
- ⚠ LETTER "A" IN MODEL NUMBER DESIGNATES, AMBIENT UNIT.
- ⚠ STANDARD CONTROL PANEL LEFT HAND MOUNT, OPTIONAL RIGHT HAND MOUNT, OR REMOTE. PLEASE SPECIFY.
- ⚠ DIMENSIONS IN INCHES [CENTIMETERS].

MODEL ⚠	NOZZLE WIDTH "A"	MOUNTING WIDTH "B"	UNIT WIDTH "C"
WD12-C-4156A	156.00 [396.24]	157.50 [400.05]	159.00 [403.86]
WD12-C-4168A	168.00 [426.72]	169.50 [430.53]	171.00 [434.34]
WD12-C-4180A/5180A	180.00 [457.20]	181.50 [461.01]	183.00 [464.82]
WD12-C-4192A/5192A	192.00 [487.68]	193.50 [491.49]	195.00 [495.30]

PROJECT		
LOCATION		
ARCHITECT		
ENGINEER		
DWG. NO.	WD12-C-AMB4	TITLE: BERNER
DATE	21JAN2021	MODEL WD12-C AIR CURTAIN
BY	S. Beil	WASHDOWN DUTY AMBIENT SYSTEM TOP INTAKE
REPLACES	-	
BY	-	BERNER INTERNATIONAL CORP. NEW CASTLE, PA.