



INDUSTRIAL WASHDOWN DUTY 14

Ambient (Unheated) Air Curtain

Data Sheet

Recommended for Mounting Heights to 14' (environmental separation) and 12' (insect control)

STANDARD CONSTRUCTION

- 1 hp single speed washdown duty totally enclosed motor(s)
- Stainless steel cabinet with stainless steel inlet screen & access panels
- Stainless steel blower wheels & housings
- Front air intake
- High efficiency Pro-V Nozzle

5 Year
Limited
Warranty



MODEL	Nozzle Width (in)	Max Vel. at Nozzle (fpm)	Avg. Outlet Vel. (fpm)	Air Volume (cfm)	Outlet Vel. Uniformity	Power Rating (kW)	Motor(s) @ hp	Net Wt. (lbs)
WD14-C-1036A	36.00	7,567	2,738	2,396	87%	1.12	1 @ 1	103
WD14-C-1042A	42.00	7,040	2,435	2,486	81%	1.12	1 @ 1	109
WD14-C-1048A	48.00	7,175	2,173	2,535	84%	1.25	1 @ 1	114
WD14-C-1060A	66.00	6,886	1,620	2,598	80%	1.28	1 @ 1	125
WD14-C-2060A	66.00	7,520	3,136	4,574	97%	2.07	2 @ 1	175
WD14-C-2072A	72.00	7,567	2,738	4,792	87%	2.24	2 @ 1	184
WD14-C-2078A	78.00	7,040	2,575	4,882	81%	2.24	2 @ 1	190
WD14-C-2084A	84.00	7,040	2,435	4,972	81%	2.24	2 @ 1	195
WD14-C-2096A	99.00	7,175	2,173	5,070	84%	2.50	2 @ 1	205
WD14-C-3096A	99.00	7,567	2,987	6,970	87%	3.19	3 @ 1	249
WD14-C-2108A	108.00	6,886	1,956	5,133	80%	2.53	2 @ 1	248
WD14-C-3108A	108.00	7,567	2,738	7,188	87%	3.36	3 @ 1	292
WD14-C-2120A	117.00	6,886	1,827	5,197	80%	2.56	2 @ 1	255
WD14-C-3120A	117.00	7,040	2,526	7,368	81%	3.36	3 @ 1	299
WD14-C-3132A	132.00	7,040	2,340	7,507	81%	3.49	3 @ 1	320
WD14-C-3144A	144.00	7,175	2,173	7,605	84%	3.75	3 @ 1	334
WD14-C-4144A	144.00	7,567	2,738	9,584	87%	4.48	4 @ 1	378
WD14-C-4156A	156.00	7,040	2,575	9,764	81%	4.48	4 @ 1	394
WD14-C-4168A	168.00	7,040	2,435	9,944	81%	4.48	4 @ 1	406
WD14-C-4180A	180.00	7,040	2,295	10,042	81%	4.74	4 @ 1	419
WD14-C-5180A	180.00	7,567	2,738	11,980	87%	5.60	5 @ 1	463
WD14-C-4192A	192.00	7,175	2,173	10,140	84%	5.00	4 @ 1	431
WD14-C-5192A	192.00	7,175	2,580	12,040	84%	5.69	5 @ 1	475

NOTES:

1. Operation at 50 Hz will generate approximately a 17% reduction in air performance.
2. Consult factory for vertically mounted units.

Berner does not recommend WD14-C-1060A, WD14-C-2108A and WD14-C-2120A, exist only as an equivalent to competitors' models. See sheet EP-410WD for amp draws/total load requirements.

MODEL NUMBER CONFIGURATION

WD14-C-1 036 A A-F-SS

Series	# of Motors	Opening Width	Heat	Voltage	Intake	Cabinet Finish
WD14-C	1, 2, 3, 4, 5	036" - 192"	A=Ambient	*A=120/1/60 B=208/1/60 J=240/1/60 D=208/3/60 E=240/3/60 H=480/3/60 I=600/3/60	F=Front	SS=Stainless Steel

VELOCITY PROFILE: Model WD14-C-1036A			
Distance from Nozzle (ft)	3	6.5	10
Core Velocity (fpm)	3822	2467	2133

Berner reserves the right to alter specifications without prior notice.

www.berner.com **Berner International** 800.245.4455
111 Progress Ave. / New Castle / PA / 16101 / USA

DS-410-WD
November, 2023



INDUSTRIAL WASHDOWN-DUTY 14

Ambient (Unheated) Air Curtain
Electrical Performance Sheet

MODEL	120/1/60 (voltage code A) MOTOR AMP DRAW = 12.6 each			208/1/60 (voltage code B) MOTOR AMP DRAW = 6.5 each			240/1/60 (voltage code J) MOTOR AMP DRAW = 6.5 each			208/3/60 (voltage code D) MOTOR AMP DRAW = 4.8 each		
	# CKTS	AMPS PER CIRCUIT	BREAKER RATING PER CIRCUIT	# CKTS	AMPS PER CIRCUIT	BREAKER RATING PER CIRCUIT	# CKTS	AMPS PER CIRCUIT	BREAKER RATING PER CIRCUIT	# CKTS	AMPS PER CIRCUIT	BREAKER RATING PER CIRCUIT
WD14-C-1036A WD14-C-1042A WD14-C-1048A WD14-C-1060A	1	12.6	20	1	6.5	15	1	6.5	15	1	4.8	15
WD14-C-2060A WD14-C-2072A WD14-C-2078A WD14-C-2084A WD14-C-2096A WD14-C-2108A WD14-C-2120A	1	25.2	35	1	13.0	20	1	13.0	20	1	9.6	15
WD14-C-3096A WD14-C-3108A WD14-C-3120A WD14-C-3132A WD14-C-3144A	1	37.8	50	1	19.5	30	1	19.5	30	1	14.4	20
WD14-C-4144A WD14-C-4156A WD14-C-4168A WD14-C-4180A WD14-C-4192A	1	50.4	70	1	26.0	35	1	26.0	35	1	19.2	25
WD14-C-5180A WD14-C-5192A	1	63.0	100	1	32.5	45	1	32.5	45	1	24.0	30

Berner reserves the right to alter specifications without prior notice.



INDUSTRIAL WASHDOWN-DUTY 14

Ambient (Unheated) Air Curtain
Electrical Performance Sheet

MODEL	240/3/60 (voltage code E) MOTOR AMP DRAW = 4.6 each			480/3/60 (voltage code H) MOTOR AMP DRAW = 2.3 each			600/3/60 (voltage code I) MOTOR AMP DRAW = 1.4 each		
	# CKTS	AMPS PER CIRCUIT	BREAKER RATING PER CIRCUIT	# CKTS	AMPS PER CIRCUIT	BREAKER RATING PER CIRCUIT	# CKTS	AMPS PER CIRCUIT	BREAKER RATING PER CIRCUIT
WD14-C-1036A WD14-C-1042A WD14-C-1048A WD14-C-1060A	1	4.6	15	1	2.3	15	1	1.4	15
WD14-C-2060A WD14-C-2072A WD14-C-2078A WD14-C-2084A WD14-C-2096A WD14-C-2108A WD14-C-2120A	1	9.2	15	1	4.6	15	1	2.8	15
WD14-C-3096A WD14-C-3108A WD14-C-3120A WD14-C-3132A WD14-C-3144A	1	13.8	20	1	6.9	15	1	4.2	15
WD14-C-4144A WD14-C-4156A WD14-C-4168A WD14-C-4180A WD14-C-4192A	1	18.4	25	1	9.2	15	1	5.6	15
WD14-C-5180A WD14-C-5192A	1	23.0	30	1	11.5	15	1	7.0	15

Berner reserves the right to alter specifications without prior notice.

WD14-C AMBIENT SYSTEM

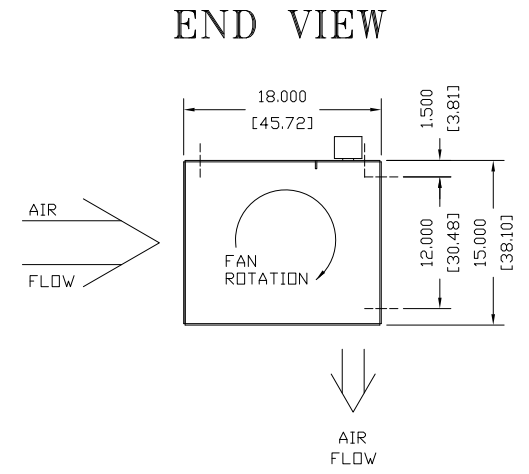
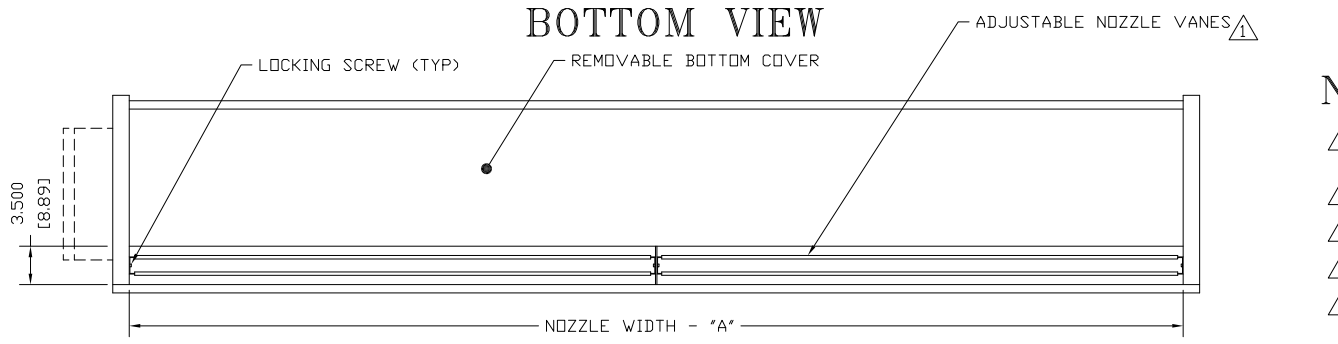
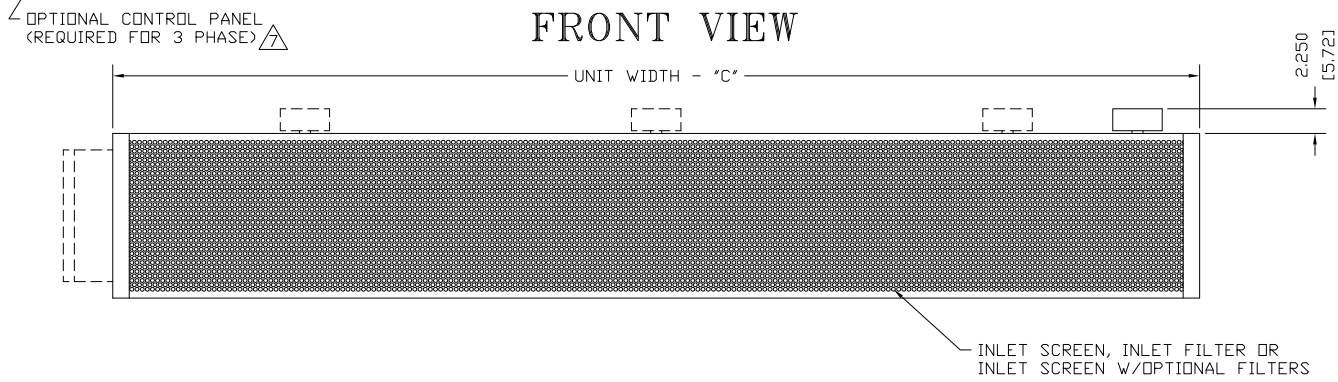
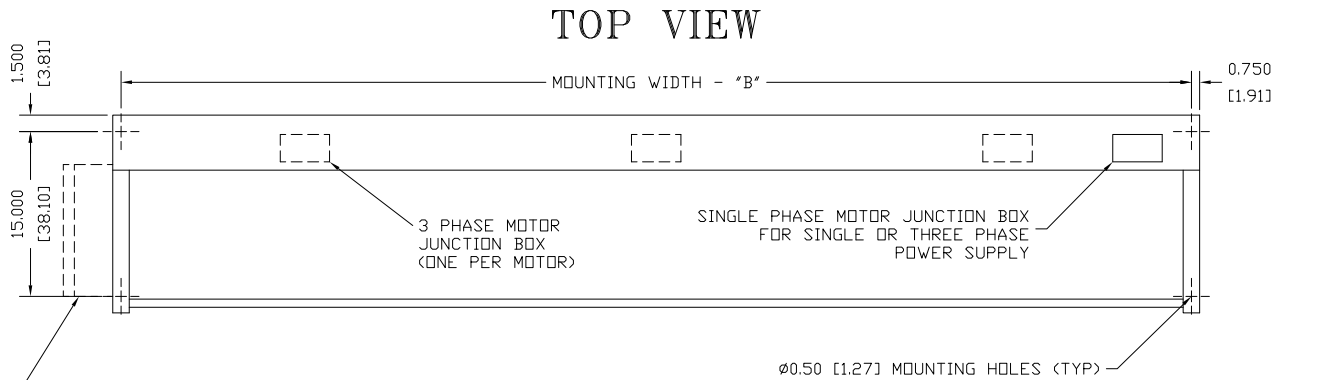

NOTES:

- 1 AIR CURTAIN MUST BE INSTALLED SO AIR STREAM IS NOT OBSTRUCTED WHEN DEFLECTED 20° TO EITHER SIDE OF C.
- 2 ELECTRICAL CONNECTIONS TO BE FLEXIBLE.
- 3 FIELD VERIFY DIMENSIONS.
- 4 ANCHORS TO SUPPORTING STRUCTURE BY OTHERS.
- 5 ADEQUACY OF SUPPORTING STRUCTURE IS TO BE VERIFIED BY A PROFESSIONAL STRUCTURAL ENGINEER.
- 6 LETTER "A" IN MODEL NUMBER DESIGNATES, AMBIENT UNIT.
- 7 STANDARD CONTROL PANEL LEFT HAND MOUNT, OPTIONAL RIGHT HAND MOUNT, OR REMOTE. PLEASE SPECIFY.
- 8 DIMENSIONS IN INCHES (CENTIMETERS).

MODEL	NOZZLE WIDTH "A"	MOUNTING WIDTH "B"	UNIT WIDTH "C"
WD14-C-1036A	36.00 [91.44]	37.50 [95.25]	39.00 [99.06]
WD14-C-1042A	42.00 [106.68]	43.50 [110.49]	45.00 [114.30]
WD14-C-1048A	48.00 [121.92]	49.50 [125.73]	51.00 [129.54]
WD14-C-1060A/2060A	66.00 [167.64]	67.50 [171.45]	69.00 [175.26]
WD14-C-2072A	72.00 [182.88]	73.50 [186.69]	75.00 [190.50]
WD14-C-2078A	78.00 [192.12]	79.50 [201.93]	81.00 [205.74]
WD14-C-2084A	84.00 [213.36]	85.50 [217.17]	87.00 [220.98]
WD14-C-2096A/3096A	99.00 [251.46]	100.50 [255.27]	102.00 [259.08]
WD14-C-2108A/3108A	108.00 [274.32]	109.50 [278.13]	111.00 [281.94]
WD14-C-2120A/3120A	117.00 [297.18]	118.50 [300.99]	120.00 [304.80]
WD14-C-3132A	132.00 [335.28]	133.50 [339.09]	135.00 [342.90]
WD14-C-3144A/4144A	144.00 [365.76]	145.50 [369.57]	147.00 [373.38]

PROJECT		TITLE:	BERNER
LOCATION		DATE	21JAN2021
ARCHITECT		BY	S. Beil
ENGINEER		REPLACES	-
		BY	-
		MODEL WD14-C AIR CURTAIN WASHDOWN DUTY AMBIENT SYSTEM	
		BERNER INTERNATIONAL CORP. NEW CASTLE, PA.	

TOP VIEW

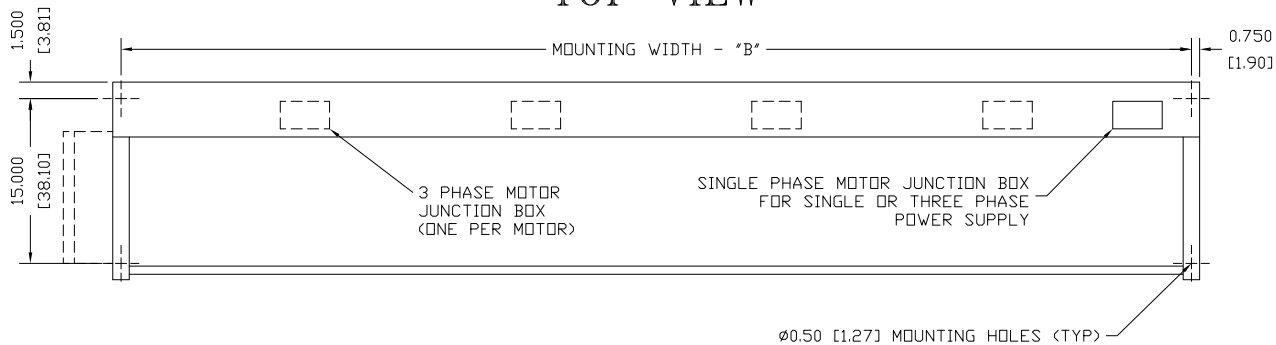

FRONT VIEW

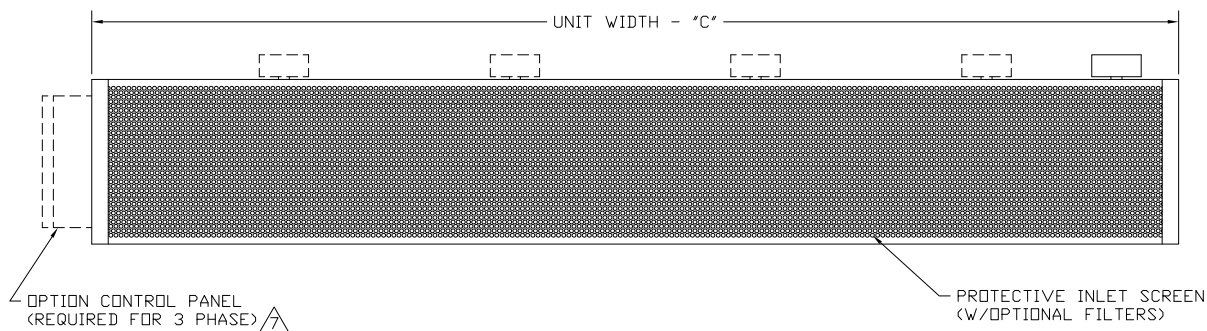

BOTTOM VIEW

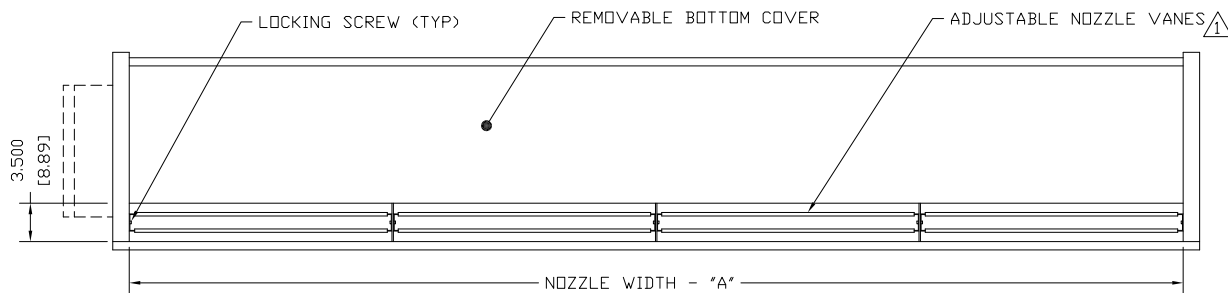

MODEL ⚠	NOZZLE WIDTH "A"	MOUNTING WIDTH "B"	UNIT WIDTH "C"
WD14-C-4156A	156.00 [396.24]	157.50 [400.05]	159.00 [403.86]
WD14-C-4168A	168.00 [426.72]	169.50 [430.53]	171.00 [434.34]
WD14-C-4180A/5180A	180.00 [457.20]	181.50 [461.01]	183.00 [464.82]
WD14-C-4192A/5192A	192.00 [487.68]	193.50 [491.49]	195.00 [495.30]

WD14-C AMBIENT SYSTEM

END VIEW

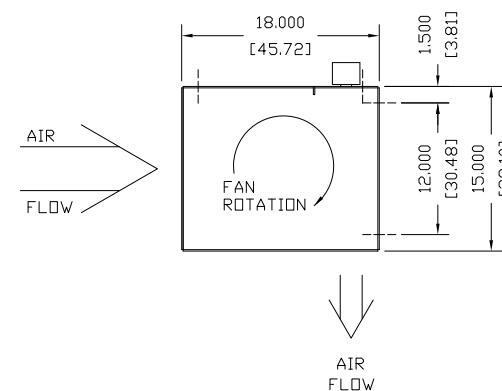

NOTES:

- ⚠ AIR CURTAIN MUST BE INSTALLED SO AIR STREAM IS NOT OBSTRUCTED WHEN DEFLECTED 20° TO EITHER SIDE OF C.
- ⚠ ELECTRICAL CONNECTIONS TO BE FLEXIBLE.
- ⚠ FIELD VERIFY DIMENSIONS.
- ⚠ ANCHORS TO SUPPORTING STRUCTURE BY OTHERS.
- ⚠ ADEQUACY OF SUPPORTING STRUCTURE IS TO BE VERIFIED BY A PROFESSIONAL STRUCTURAL ENGINEER.
- ⚠ LETTER "A" IN MODEL NUMBER DESIGNATES, AMBIENT UNIT.
- ⚠ STANDARD CONTROL PANEL LEFT HAND MOUNT, OPTIONAL RIGHT HAND MOUNT, OR REMOTE. PLEASE SPECIFY.
- ⚠ DIMENSIONS IN INCHES (CENTIMETERS).

PROJECT		
LOCATION		
ARCHITECT		
ENGINEER		
DWG. NO.	WD14-C-AMB2	TITLE: BERNER
DATE	21JAN2021	MODEL WD14-C AIR CURTAIN
BY	S. Beil	WASHDOWN DUTY AMBIENT SYSTEM
REPLACES	-	BERNER INTERNATIONAL CORP. NEW CASTLE, PA.
BY	-	

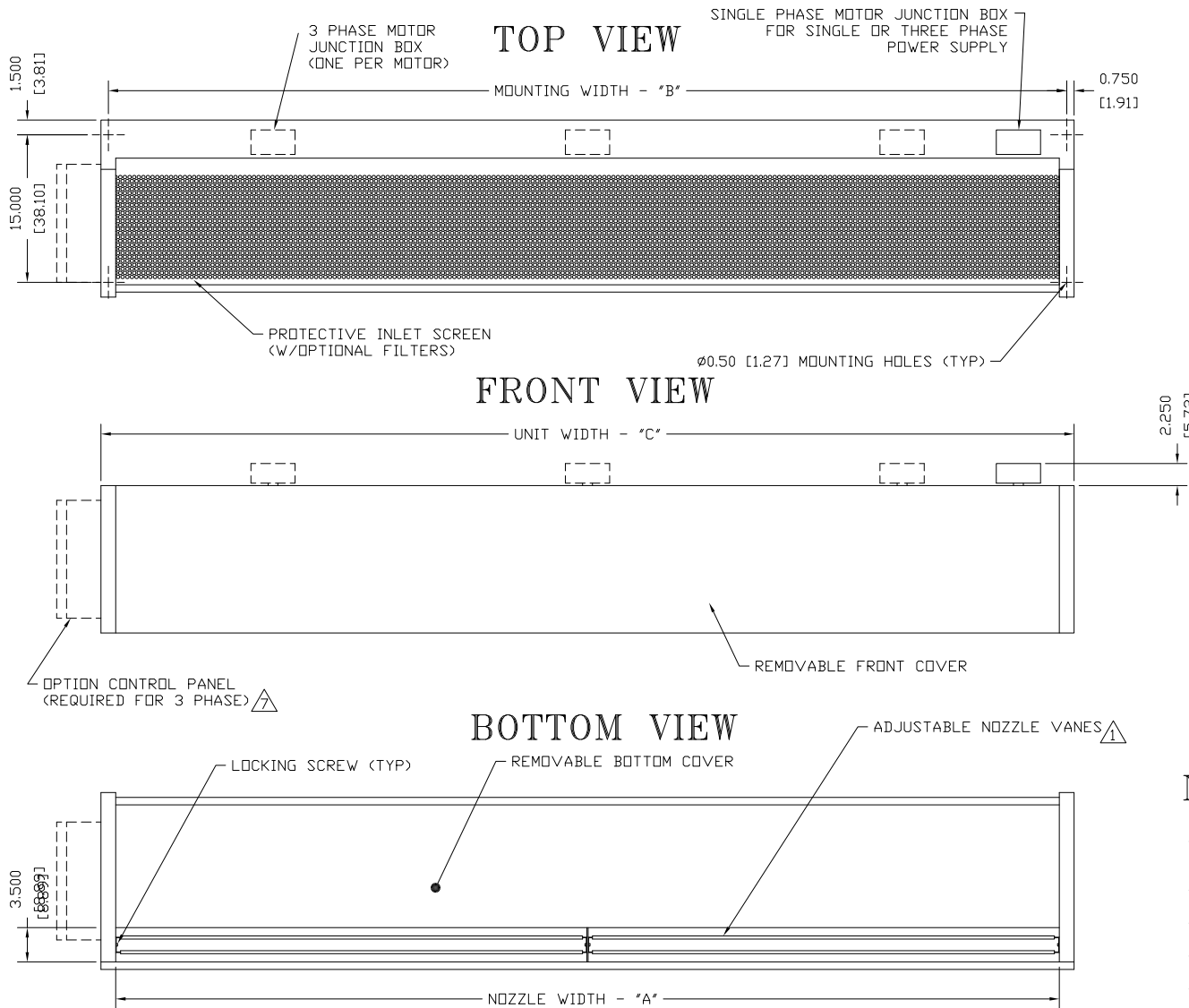

WD14-C AMBIENT SYSTEM TOP INTAKE

END VIEW

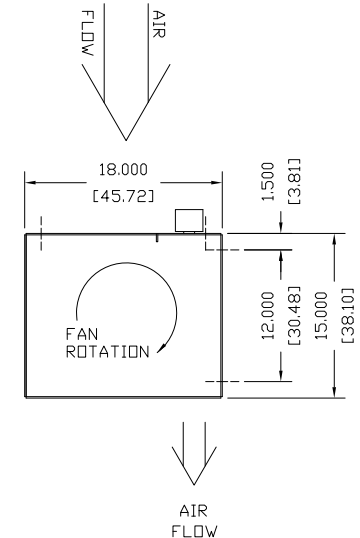

NOTES:

- 1 AIR CURTAIN MUST BE INSTALLED SO AIR STREAM IS NOT OBSTRUCTED WHEN DEFLECTED 20° TO EITHER SIDE OF ϕ .
- 2 ELECTRICAL CONNECTIONS TO BE FLEXIBLE.
- 3 FIELD VERIFY DIMENSIONS.
- 4 ANCHORS TO SUPPORTING STRUCTURE BY OTHERS.
- 5 ADEQUACY OF SUPPORTING STRUCTURE IS TO BE VERIFIED BY A PROFESSIONAL STRUCTURAL ENGINEER.
- 6 LETTER "A" IN MODEL NUMBER DESIGNATES, AMBIENT UNIT.
- 7 STANDARD CONTROL PANEL LEFT HAND MOUNT, OPTIONAL RIGHT HAND MOUNT, OR REMOTE. PLEASE SPECIFY.
- 8 DIMENSIONS IN INCHES [CENTIMETERS].

MODEL [△]	NOZZLE WIDTH "A"	MOUNTING WIDTH "B"	UNIT WIDTH "C"
WD14-C-1036A	36.00 [91.44]	37.50 [95.25]	39.00 [99.06]
WD14-C-1042A	42.00 [106.68]	43.50 [110.49]	45.00 [114.30]
WD14-C-1048A	48.00 [121.92]	49.50 [125.73]	51.00 [129.54]
WD14-C-1060A/2060A	66.00 [167.64]	67.50 [171.45]	69.00 [175.26]
WD14-C-2072A	72.00 [182.88]	73.50 [186.69]	75.00 [190.50]
WD14-C-2078A	78.00 [192.12]	79.50 [201.93]	81.00 [205.74]
WD14-C-2084A	84.00 [213.36]	85.50 [217.17]	87.00 [220.98]
WD14-C-2096A/3096A	99.00 [251.46]	100.50 [255.27]	102.00 [259.08]
WD14-C-2108A/3108A	108.00 [274.32]	109.50 [278.13]	111.00 [281.94]
WD14-C-2120A/3120A	117.00 [297.18]	118.50 [300.99]	120.00 [304.80]
WD14-C-3132A	132.00 [335.28]	133.50 [339.09]	135.00 [342.90]
WD14-C-3144A/4144A	144.00 [365.76]	145.50 [369.57]	147.00 [373.38]

PROJECT		
LOCATION		
ARCHITECT		
ENGINEER		
DWG. NO.	WD14-C-AMB3	TITLE: BERNER
DATE	21JAN2021	MODEL WD14-C AIR CURTAIN
BY	S. Beil	WASHDOWN DUTY AMBIENT SYSTEM TOP INTAKE
REPLACES	-	
BY	-	BERNER INTERNATIONAL CORP. NEW CASTLE, PA.

WD14-C AMBIENT SYSTEM TOP INTAKE

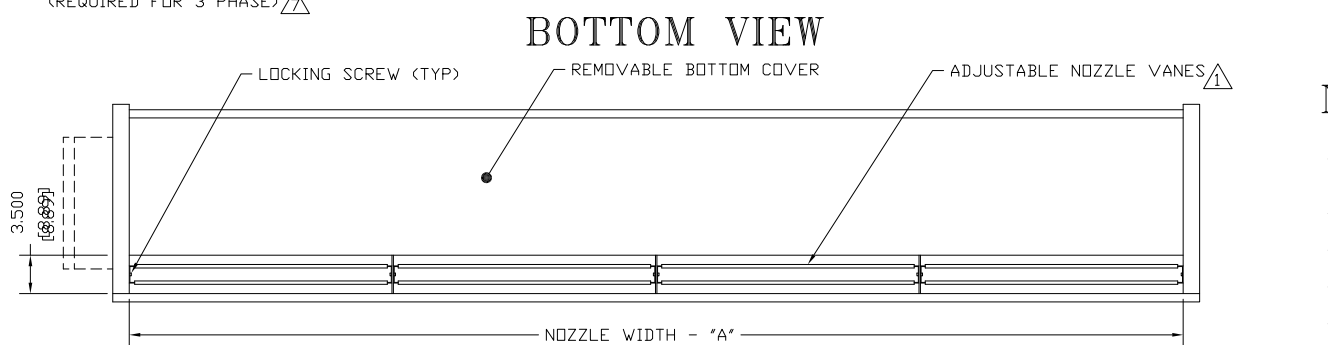
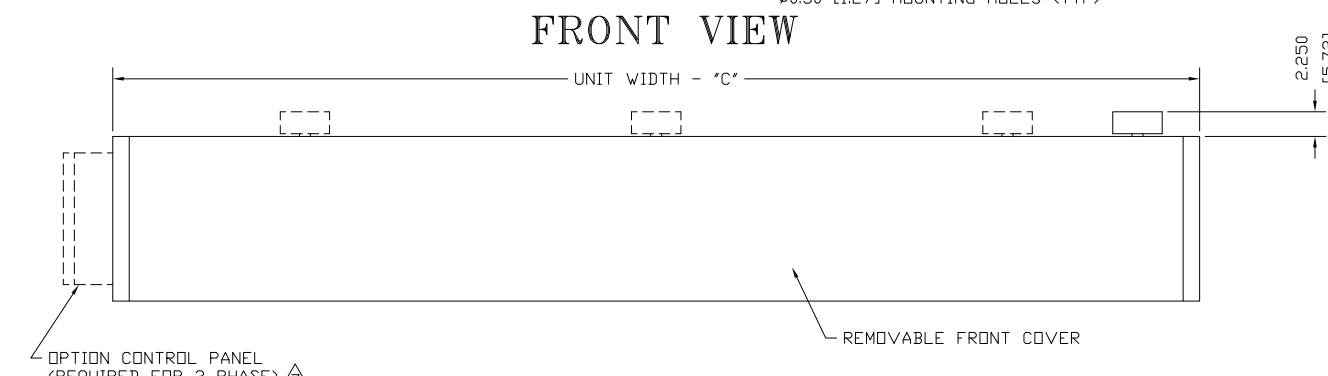
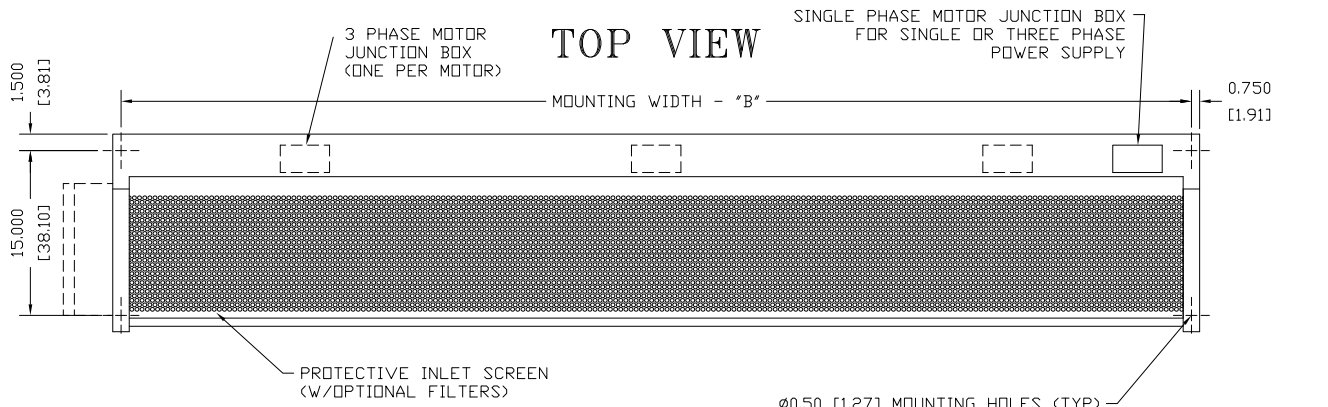

END VIEW

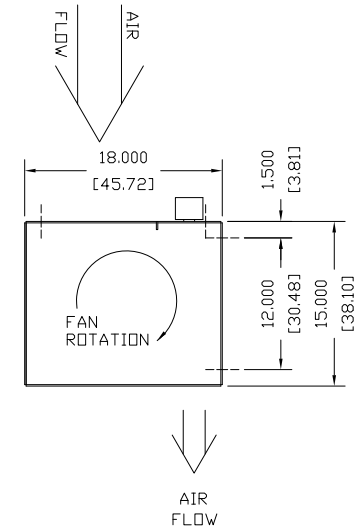

MODEL [△]	NOZZLE WIDTH "A"	MOUNTING WIDTH "B"	UNIT WIDTH "C"
WD14-C-4156A	156.00 [396.24]	157.50 [400.05]	159.00 [403.86]
WD14-C-4168A	168.00 [426.72]	169.50 [430.53]	171.00 [434.34]
WD14-C-4180A/5180A	180.00 [457.20]	181.50 [461.01]	183.00 [464.82]
WD14-C-4192A/5192A	192.00 [487.68]	193.50 [491.49]	195.00 [495.30]

NOTES:

- ¹ AIR CURTAIN MUST BE INSTALLED SO AIR STREAM IS NOT OBSTRUCTED WHEN DEFLECTED 20° TO EITHER SIDE OF ϕ .
- ² ELECTRICAL CONNECTIONS TO BE FLEXIBLE.
- ³ FIELD VERIFY DIMENSIONS.
- ⁴ ANCHORS TO SUPPORTING STRUCTURE BY OTHERS.
- ⁵ ADEQUACY OF SUPPORTING STRUCTURE IS TO BE VERIFIED BY A PROFESSIONAL STRUCTURAL ENGINEER.
- ⁶ LETTER "A" IN MODEL NUMBER DESIGNATES, AMBIENT UNIT.
- ⁷ STANDARD CONTROL PANEL LEFT HAND MOUNT, OPTIONAL RIGHT HAND MOUNT, OR REMOTE. PLEASE SPECIFY.
- ⁸ DIMENSIONS IN INCHES (CENTIMETERS).

PROJECT		
LOCATION		
ARCHITECT		
ENGINEER		
DWG. NO.	WD14-C-AMB4	TITLE: BERNER
DATE	21JAN2021	MODEL WD14-C AIR CURTAIN
BY	S. Beil	WASHDOWN DUTY AMBIENT SYSTEM TOP INTAKE
REPLACES	-	
BY	-	BERNER INTERNATIONAL CORP. NEW CASTLE, PA.