



INDUSTRIAL WASHDOWN DUTY 16

Ambient (Unheated) Air Curtain

Data Sheet

Recommended for Mounting Heights to 16' (environmental separation) and 14' (insect control)

STANDARD CONSTRUCTION

- Single speed washdown duty totally enclosed motor(s)
- Stainless steel cabinet with stainless steel inlet screen & access panels
- Stainless steel blower wheels & housings
- Front air intake
- High efficiency Pro-V Nozzle

5 Year
Limited
Warranty



MODEL	Nozzle Width (in)	Max Vel. at Nozzle (fpm)	Avg. Outlet Vel. (fpm)	Air Volume (cfm)	Outlet Vel. Uniformity	Power Rating (kW)	Motor(s) @ hp	Net Wt. (lbs)
WD16-C-1060A	60.00	5,145	3,302	5,359	85%	2.80	1 @ 3	370
WD16-C-1072A	72.00	5,005	2,944	6,256	91%	2.90	1 @ 3	410
WD16-C-1084A	84.00	4,644	2,732	6,772	89%	3.00	1 @ 3	450
WD16-C-1096A	96.00	5,352	3,148	8,920	87%	4.10	1 @ 5	550
WD16-C-1108A	108.00	5,236	3,080	9,817	86%	4.20	1 @ 5	670
WD16-C-1120A	117.00	6,012	3,627	12,526	87%	4.80	1 @ 7.5	705
WD16-C-1132A	132.00	5,602	3,296	12,839	86%	4.90	1 @ 7.5	755
WD16-C-1144A	144.00	5,225	3,074	13,062	85%	5.40	1 @ 7.5	795
WD16-C-1156A	156.00	4,943	2,908	13,388	84%	5.50	1 @ 7.5	845
WD16-C-2168A	168.00	5,203	3,061	15,176	89%	7.00	1 @ 5, 1 @ 3	950
WD16-C-2180A	180.00	5,143	3,026	16,073	87%	7.10	1 @ 5, 1 @ 3	1,015
WD16-C-2192A	192.00	5,352	3,148	17,840	87%	8.20	2 @ 5	1,080

NOTE:

1. Operation at 50 Hz will generate approximately a 17% reduction in air performance.
 2. Consult factory for vertically mounted units.
- See sheet EP-420-WD for amp draws/total load requirements.

MODEL NUMBER CONFIGURATION

WD16-C-1 060 A D-F-SS

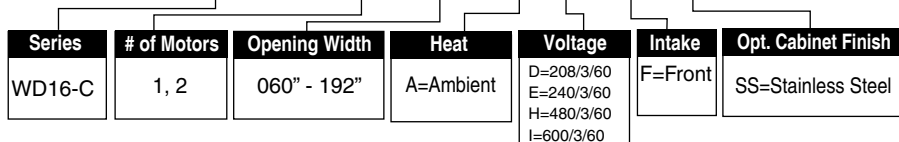

VELOCITY PROFILE: Model WD16-C-1060A				
Distance from Nozzle (in)	40	80	120	160
Core Velocity (fpm)	4227	2320	1840	1560
Uniformity (%)	89	88	88	85

Berner reserves the right to alter specifications without prior notice.



INDUSTRIAL WASHDOWN-DUTY 16

Ambient (Unheated) Air Curtain
Electrical Performance Sheet

MODEL	Qty @ HP	208/3/60 (voltage code D) MOTOR AMP DRAW PER HP			240/3/60 (voltage code E) MOTOR AMP DRAW PER HP			480/3/60 (voltage code H) MOTOR AMP DRAW PER HP		
		# CKTS	AMPS PER CIRCUIT	BREAKER RATING PER CIRCUIT	# CKTS	AMPS PER CIRCUIT	BREAKER RATING PER CIRCUIT	# CKTS	AMPS PER CIRCUIT	BREAKER RATING PER CIRCUIT
WD16-C-1060A WD16-C-1072A WD16-C-1084A	1 @ 3	1	13.1	25	1	12.2	25	1	6.1	15
WD16-C-1096A WD16-C-1108A	1 @ 5	1	17.0	35	1	15.8	35	1	7.9	20
WD16-C-1120A WD16-C-1132A WD16-C-1144A WD16-C-1156A	1 @ 7.5	1	23.0	50	1	22.0	45	1	11.0	25
WD16-C-2168A WD16-C-2180A	1 @ 3 1 @ 5	1	30.1	50	1	28.0	60	1	14.0	25
WD16-C-2192A	2 @ 5	1	34.0	60	1	31.6	60	1	15.8	25

Berner reserves the right to alter specifications without prior notice.

		600/3/60 (voltage code I) MOTOR AMP DRAW PER HP		
MODEL	Qty @ HP	# CKTS	AMPS PER CIRCUIT	BREAKER RATING PER CIRCUIT
WD16-C-1060A WD16-C-1072A WD16-C-1084A	1 @ 3	1	3.9	15
WD16-C-1096A WD16-C-1108A	1 @ 5	1	6.3	15
WD16-C-1120A WD16-C-1132A WD16-C-1144A WD16-C-1156A	1 @ 7.5	1	8.5	20
WD16-C-2168A WD16-C-2180A	1 @ 3 1 @ 5	1	10.2	20
WD16-C-2192A	2 @ 5	1	12.6	20

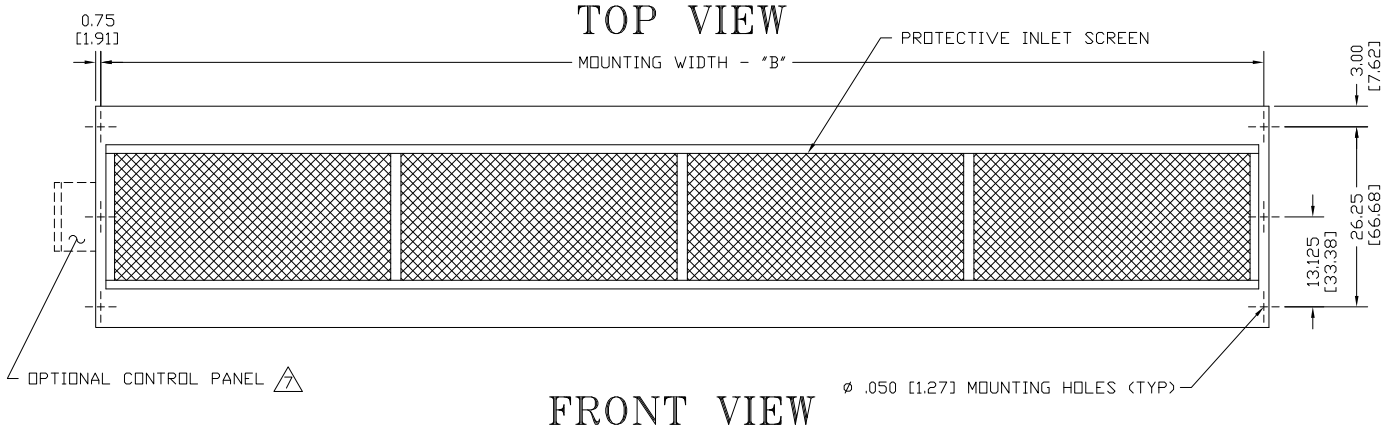

WD16-C AMBIENT SYSTEM TOP INTAKE

END VIEW

AIR FLOW

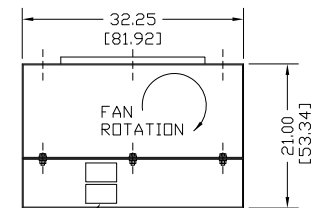

ONE JUNCTION BOX PER MOTOR
(REQUIRED FOR REMOTE PANEL)
2.75 x 4.50 x 2.00
[6.99 x 11.43 x 5.08]

AIR FLOW

BOTTOM VIEW

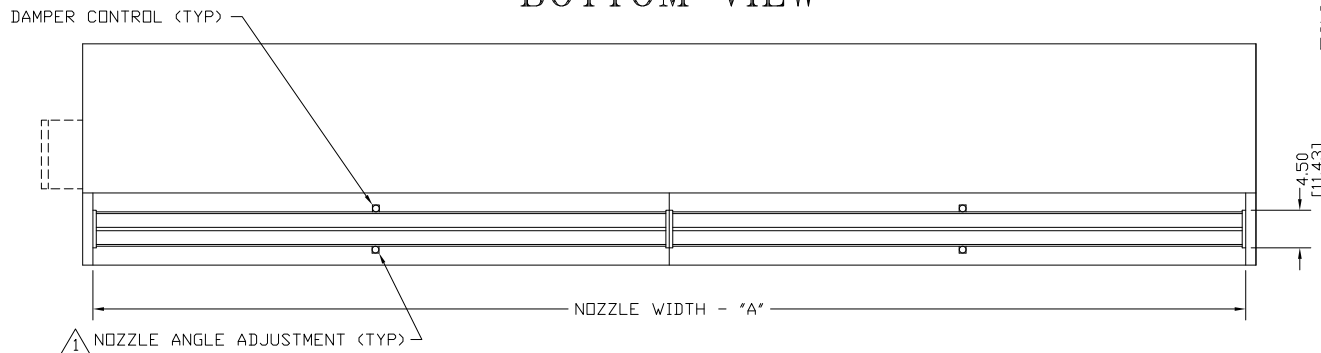

NOTES:

- 1 AIR CURTAIN MUST BE INSTALLED SO AIR STREAM IS NOT OBSTRUCTED WHEN DEFLECTED 20° TO EITHER SIDE OF \varnothing .
- 2 ELECTRICAL CONNECTIONS TO BE FLEXIBLE.
- 3 FIELD VERIFY DIMENSIONS.
- 4 ANCHORS TO SUPPORTING STRUCTURE BY OTHERS.
- 5 ADEQUACY OF SUPPORTING STRUCTURE IS TO BE VERIFIED BY A PROFESSIONAL STRUCTURAL ENGINEER.
- 6 LETTER "A" IN MODEL NUMBER DESIGNATES, AN AMBIENT UNIT. THE "T" DESIGNATES TOP INTAKE.
- 7 OPTIONAL CONTROL PANEL AVAILABLE: LEFT HAND MOUNT, RIGHT HAND MOUNT, OR REMOTE. PLEASE SPECIFY.
- 8 DIMENSIONS IN INCHES [CENTIMETERS].

MODEL	NOZZLE WIDTH "A"	MOUNTING WIDTH "B"	UNIT WIDTH "C"
WD16-C-1060A-T	60.00 [152.40]	61.50 [156.21]	63.00 [160.02]
WD16-C-1072A-T	72.00 [182.88]	73.50 [186.69]	75.00 [190.50]
WD16-C-1084A-T	84.00 [213.36]	85.50 [217.17]	87.00 [220.98]
WD16-C-1096A-T	96.00 [243.84]	97.50 [247.65]	99.00 [251.46]
WD16-C-1108A-T	108.00 [274.32]	109.50 [278.13]	111.00 [281.94]
WD16-C-1120A-T	117.00 [297.18]	118.50 [300.99]	120.00 [304.80]
WD16-C-1132A-T	132.00 [335.28]	133.50 [339.09]	135.00 [342.90]
WD16-C-1144A-T	144.00 [365.76]	145.50 [369.57]	147.00 [373.38]
WD16-C-1156A-T	156.00 [396.24]	157.50 [400.05]	159.00 [403.86]
WD16-C-2168A-T	168.00 [426.72]	169.50 [430.53]	171.00 [434.34]
WD16-C-2180A-T	180.00 [457.20]	181.50 [461.01]	183.00 [464.82]
WD16-C-2192A-T	192.00 [487.68]	193.50 [491.49]	195.00 [495.30]

PROJECT		
LOCATION		
ARCHITECT		
ENGINEER		
DWG. NO.	WD16-C-AMBI	TITLE: BERNER
DATE	21JAN2021	MODEL WD16-C AIR CURTAIN
BY	S. Beil	WASHDOWN DUTY TOP INTAKE AMBIENT SYSTEM
REPLACES	-	
BY	-	BERNER INTERNATIONAL CORP. NEW CASTLE, PA.

WD16-C AMBIENT SYSTEM FRONT INTAKE

TOP VIEW

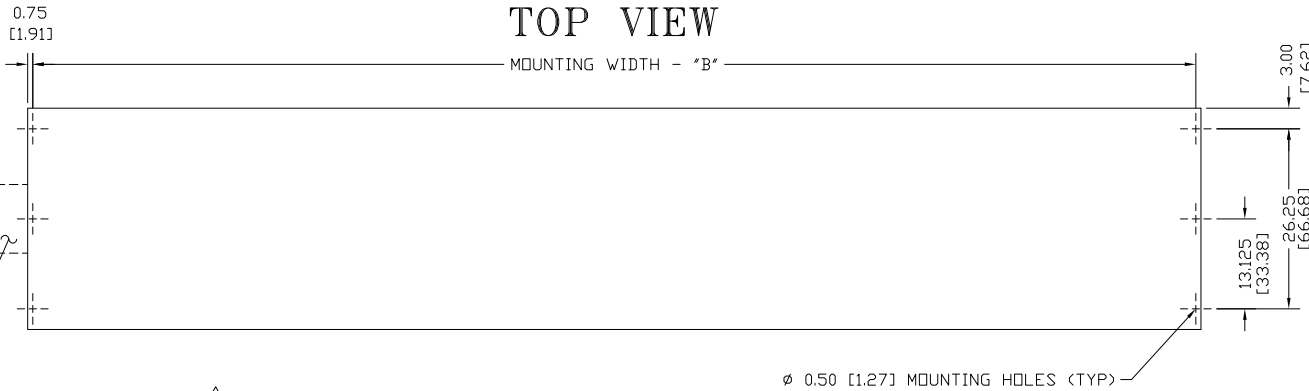

OPTIONAL CONTROL PANEL

FRONT VIEW

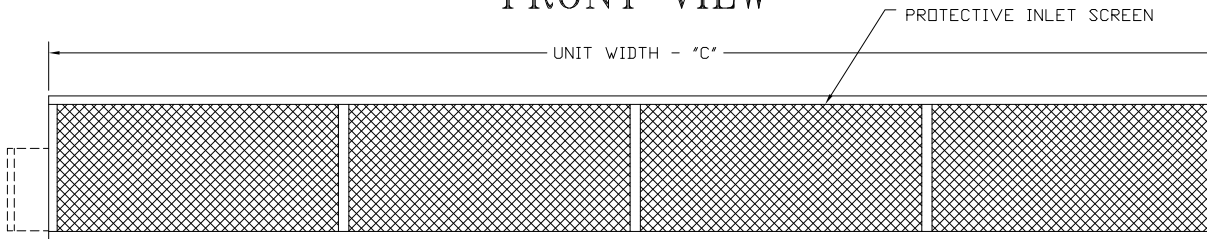

BOTTOM VIEW

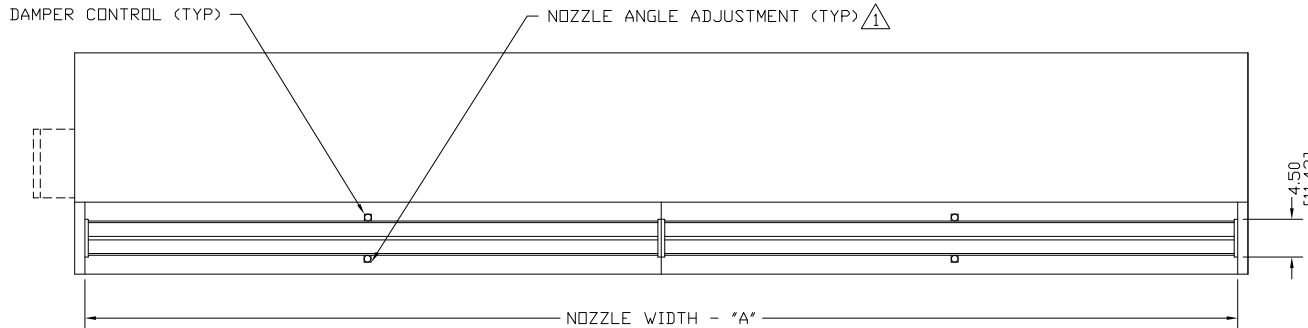

END VIEW

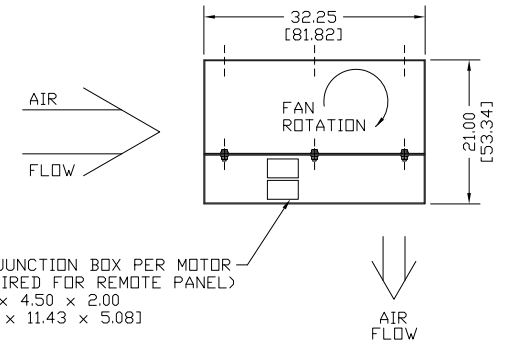

NOTES:

- AIR CURTAIN MUST BE INSTALLED SO AIR STREAM IS NOT OBSTRUCTED WHEN DEFLECTED 20° TO EITHER SIDE OF \bar{C} .
- ELECTRICAL CONNECTIONS TO BE FLEXIBLE.
- FIELD VERIFY DIMENSIONS.
- ANCHORS TO SUPPORTING STRUCTURE BY OTHERS.
- ADEQUACY OF SUPPORTING STRUCTURE IS TO BE VERIFIED BY A PROFESSIONAL STRUCTURAL ENGINEER.
- LETTER "A" IN MODEL NUMBER DESIGNATES, AN AMBIENT UNIT. THE "F" DESIGNATES FRONT INTAKE.
- OPTIONAL CONTROL PANEL AVAILABLE: LEFT HAND MOUNT, RIGHT HAND MOUNT, OR REMOTE. PLEASE SPECIFY.
- DIMENSIONS IN INCHES [CENTIMETERS].

MODEL	NOZZLE WIDTH "A"	MOUNTING WIDTH "B"	UNIT WIDTH "C"
WD16-C-1060A-F	60.00 [152.40]	61.50 [156.21]	63.00 [160.02]
WD16-C-1072A-F	72.00 [182.88]	73.50 [186.69]	75.00 [190.50]
WD16-C-1084A-F	84.00 [213.36]	85.50 [217.17]	87.00 [220.98]
WD16-C-1096A-F	96.00 [243.84]	97.50 [247.65]	99.00 [251.46]
WD16-C-1108A-F	108.00 [274.32]	109.50 [278.13]	111.00 [281.94]
WD16-C-1120A-F	117.00 [297.18]	118.50 [300.99]	120.00 [304.80]
WD16-C-1132A-F	132.00 [335.28]	133.50 [339.09]	135.00 [342.90]
WD16-C-1144A-F	144.00 [365.76]	145.50 [369.57]	147.00 [373.38]
WD16-C-1156A-F	156.00 [396.24]	157.50 [400.05]	159.00 [403.86]
WD16-C-2168A-F	168.00 [426.72]	169.50 [430.53]	171.00 [434.34]
WD16-C-2180A-F	180.00 [457.20]	181.50 [461.01]	183.00 [464.82]
WD16-C-2192A-F	192.00 [487.68]	193.50 [491.49]	195.00 [495.30]

PROJECT		TITLE: BERNER
LOCATION		MODEL WD16-C AIR CURTAIN
ARCHITECT		WASHDOWN DUTY FRONT INTAKE AMBIENT SYSTEM
ENGINEER		
DWG. NO.	WD16-C-AMB2	
DATE	21JAN2021	
BY	S. Beil	
REPLACES	-	
BY	-	BERNER INTERNATIONAL CORP. NEW CASTLE, PA.